

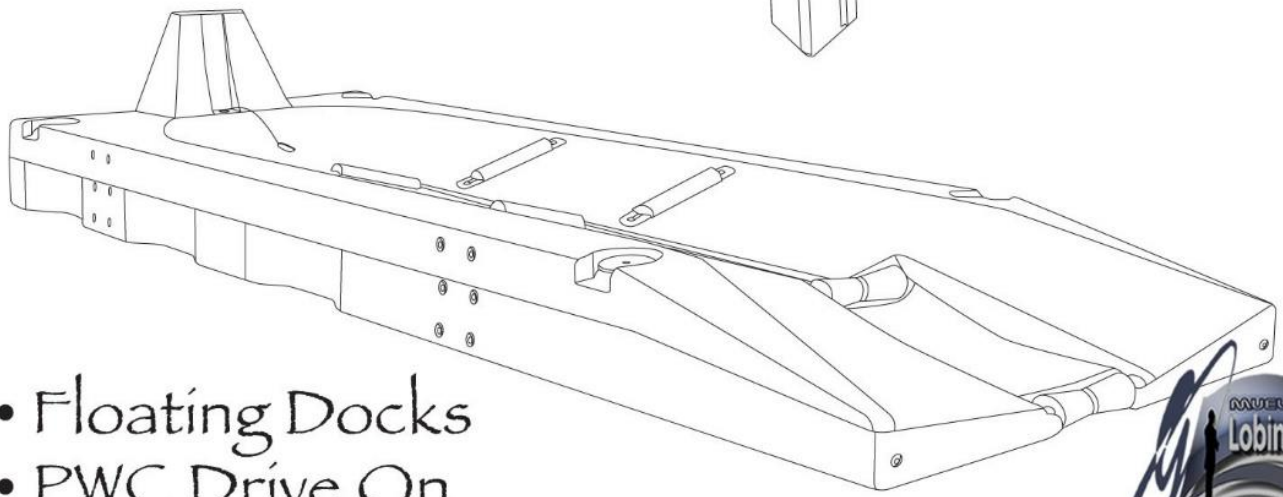

Marine Assembly Instructions

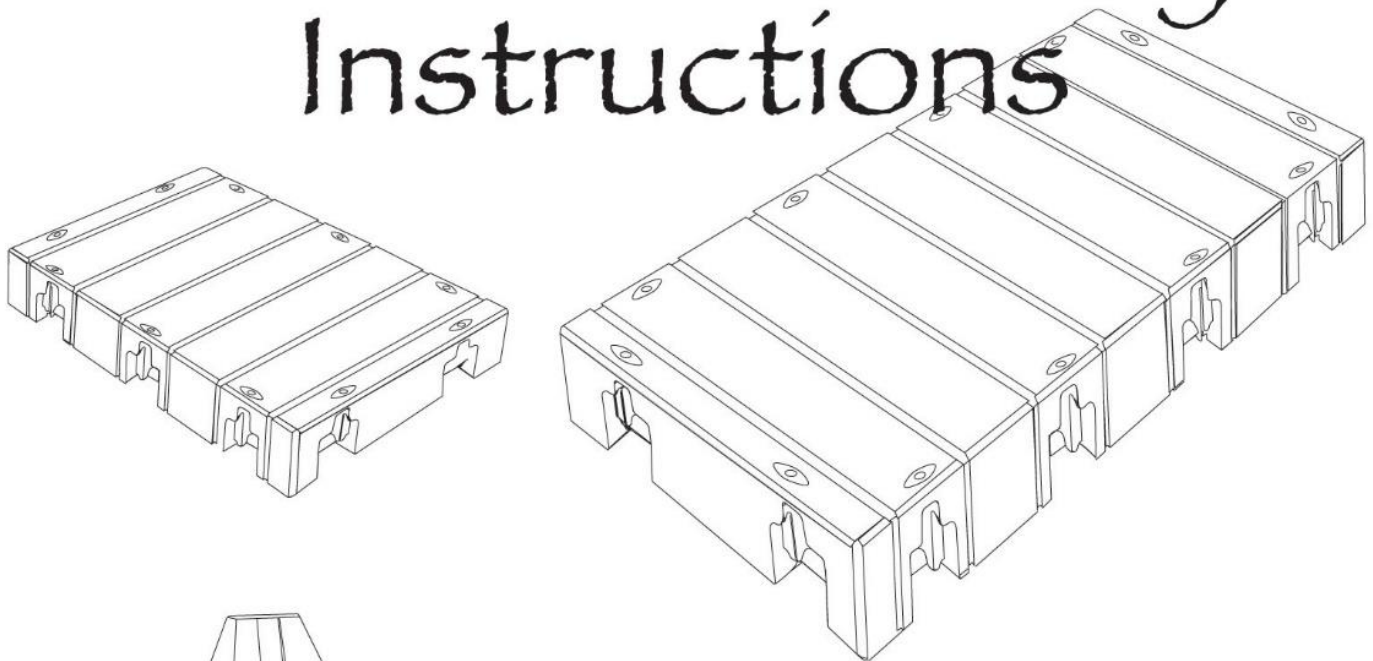

- Floating Docks
- PWC Drive On



Make a connection to Life™

ventas@lobineando.com / info@lobineando.com

2000 Series High Profile (HP) Dock

www.connectadock.com



www.lobineando.com

Tools Needed

9/16" (16 mm) Socket wrench
Long rope for holding docks to shore.

Before you begin: Determine the layout and location of your dock.

Hardware Included

3/8" x 1-1/4" (10 mm x 35 mm) Hex bolts
Hex bolts 
Diamond washers 
Bushings 

Step 1

Install Float Connectors into all Float Section sockets where other Float Sections will be attached. Secure Float Connectors into sockets with bolts, washers, and bushings provided (**hand tighten only**). Place first Float Section into the water and temporarily attach to shore with rope.

Step 2

Position yourself carefully on the floating Float Section(s). Continue adding Float Sections by placing them over the Float Connectors, shift your body weight to the new Float Section and hook into place. Secure with bolts, washers, and bushings.

Step 3

Tighten all bolts in the dock using 25 lbs/ft (3.46 kg/m) of torque. Anchor as desired. **NOTE: DO NOT SUBMERGE...** a minimum of 3" (7.62 cm) must show above the water surface for venting purposes.

Instructions for

Float Section (FS2096), (FS2024)
Float Connector (FC2020), (FC2020M)
2 or more people are needed for installation

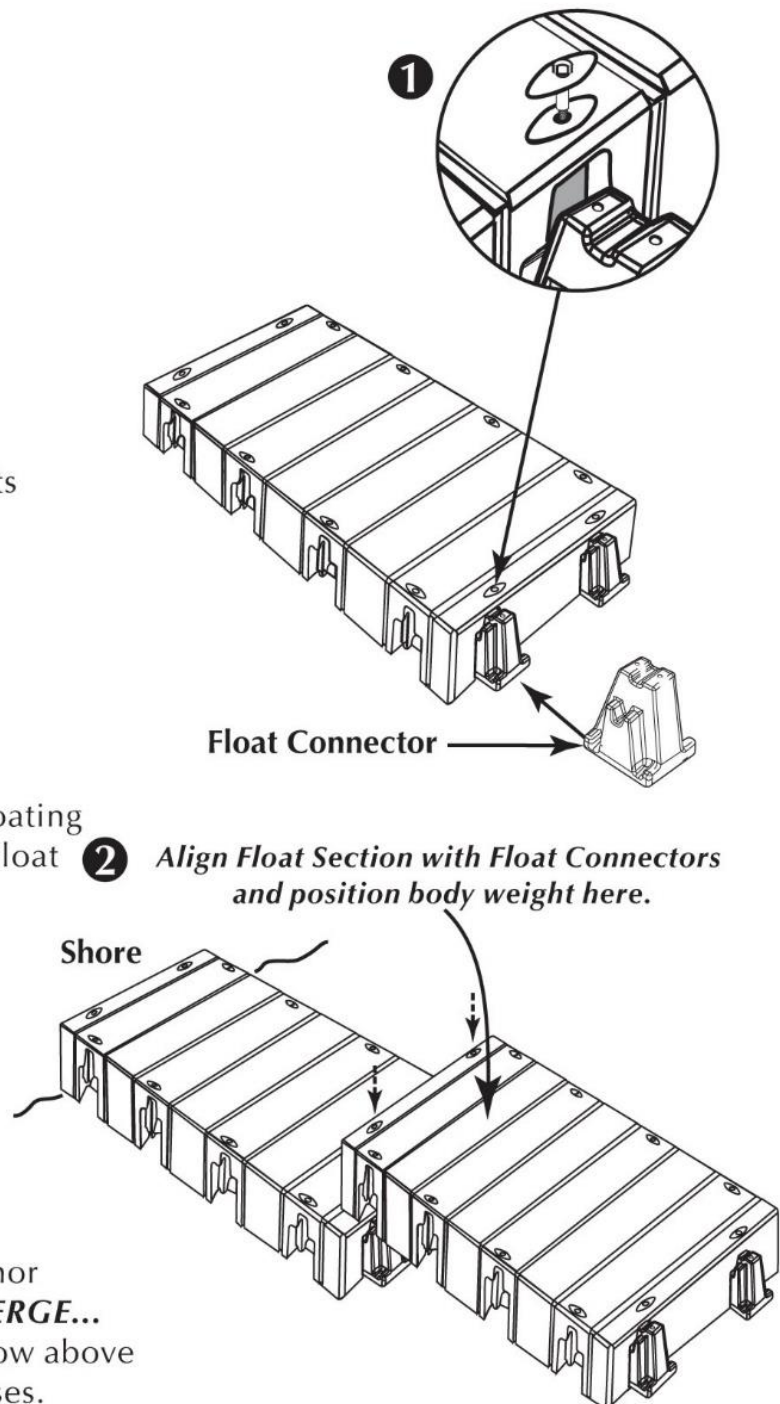

Note: Check all bolts every three months or as needed to insure all connector hardware is securely fastened.



1501 Owner Avenue, Atlantic, IA 50022 USA

ventas@lobineando.com / info@lobineando.com



2000 Series (HP) Corner Float Section

www.connectadock.com

www.lobineando.com

Tools Needed

9/16" (16 mm) Socket wrench

Instructions for:

Corner Float Section (CFS2022)

The Corner Float Section adds strength, stability and more walking space to the fingers of your dock.

Hardware Included

3/8" x 1-1/4" (10 mm x 35 mm) Hex bolts
Diamond washers
Bushings

Step 1

Install four Float Connectors into Float Section sockets where the Corner Float Section will be attached. Secure Float Connectors into sockets with bolts, washers, and bushings as shown (**Hand tighten only**).

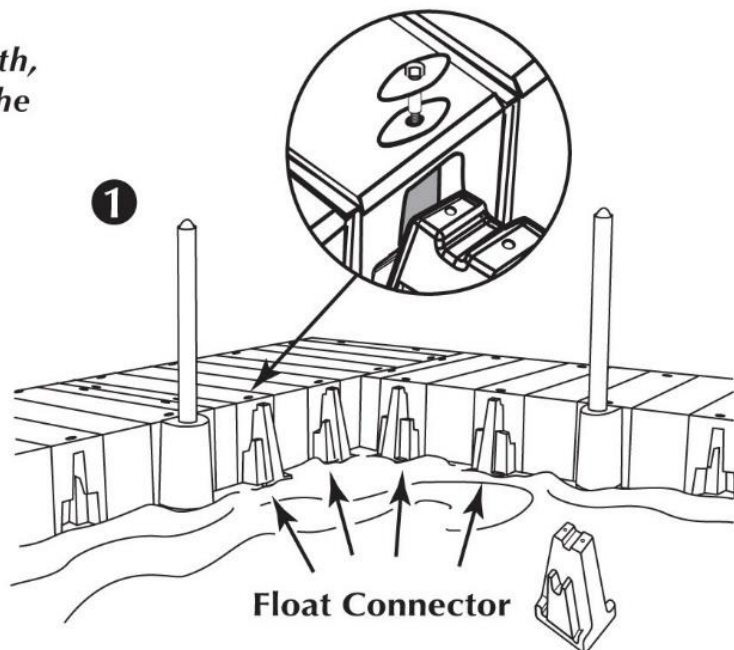

Step 2

Place the Corner Float Section over the Float Connectors, then shift your body weight carefully from the dock to the Corner Float Section to hold it in place. Secure with bolts, washers, and bushings as in Step 1.

2

Align Corner Float Section with Float Connectors

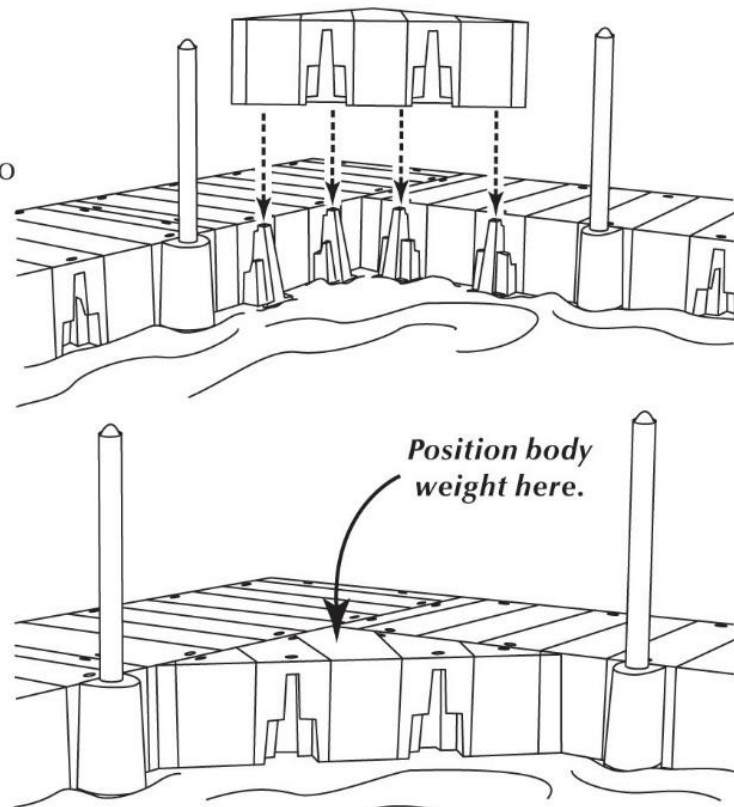

Step 3

Tighten all bolts in the dock using 25 lbs/ft (3.46 kg/m) of torque. Anchor as desired.

NOTE: DO NOT SUBMERGE...

a minimum of 2" (5.08 cm) must show above the water surface for venting purposes.

Note: Check all bolts every three months or as needed to insure all connector hardware is securely fastened.



1501 Owner Avenue, Atlantic, IA 50022 USA

ventas@lobineando.com / info@lobineando.com

2000 Series (HP) Dual Pole Connector

www.connectadock.com

www.lobineando.com

Tools Needed

9/16" (16 mm) Socket wrench

Hardware Included

3/8" x 1-1/4" (10 mm x 35 mm)

Hex bolts

Diamond washers

Bushings



Instructions for:

Dual Pole Connector (DPC2023)

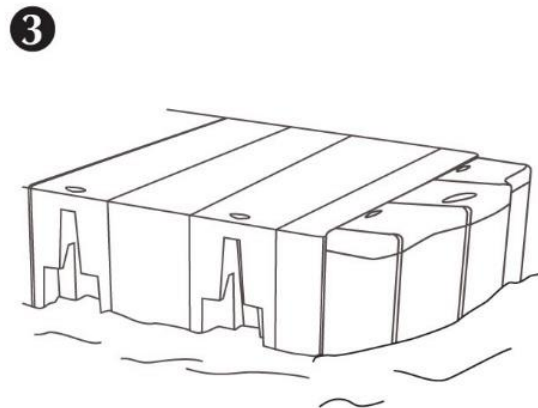
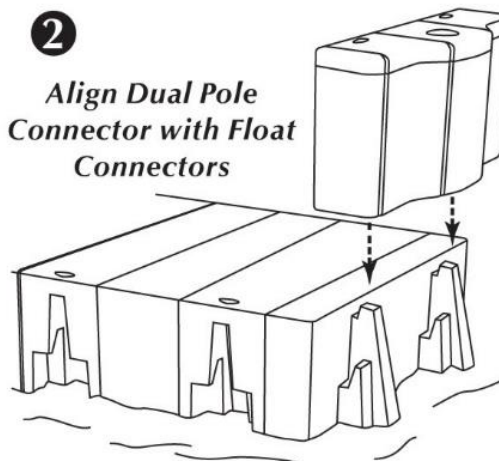
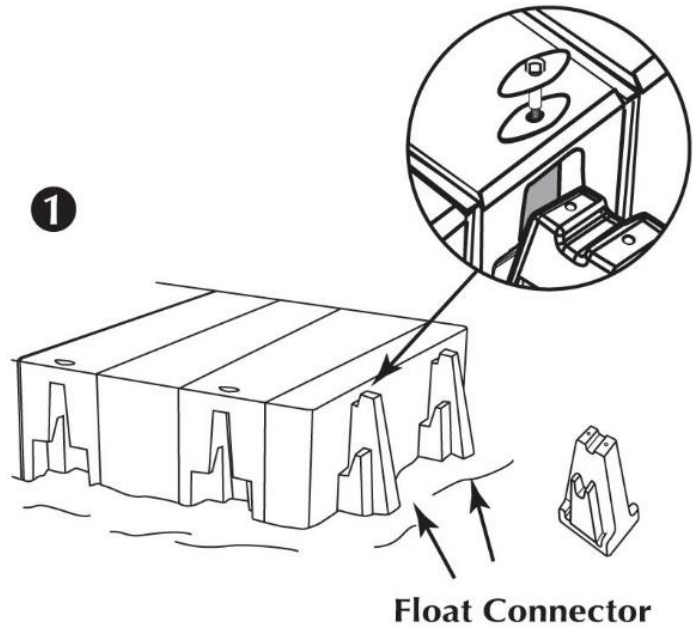

Step 1

Install two Float Connectors into Float Section sockets where the Dual Pole Connector will be attached. Secure Float Connectors into sockets with bolts, washers, and bushings as shown (*Hand tighten only*).

Step 2

Place the Dual Pole Connector over the Float Connectors, then push down on Dual Pole Connector to hold in place. Secure with bolts, washers, and bushings as in Step 1.

Step 3

Tighten all bolts in the dock using 25 lbs/ft (3.46 kg/m) of torque.

Anchor as desired.

NOTE: DO NOT SUBMERGE...

a minimum of 2" (5.08 cm) must show above the water surface for venting purposes.

Note: Check all bolts every three months or as needed to insure all connector hardware is securely fastened.



1501 Owner Avenue, Atlantic, IA 50022 USA

ventas@lobineando.com / info@lobineando.com



2000 Series (HP) Extra Flotation

www.connectadock.com

www.lobineando.com

Tools Needed

9/16" (16 mm) Socket wrench

Before you begin: Determine the layout and location of your dock. When installing a new dock, it is easier to insert the Extra Flotation before the Float Section is placed in the water. For existing docks, go to step 1.

Step 1

When installing a 2000 Series Extra Flotation to an existing dock, two Float Sections need to be removed from the water. Start by unbolting the Float Connectors from Float Section (1a). Place Float Section (1a) out of the water in location (1b).

Step 2

Unbolt the Float Connectors from the main dock section (2a). Place Float Section (2a) out of the water in location (2b).

Step 3

Insert Extra Flotation under Float Section (2b).

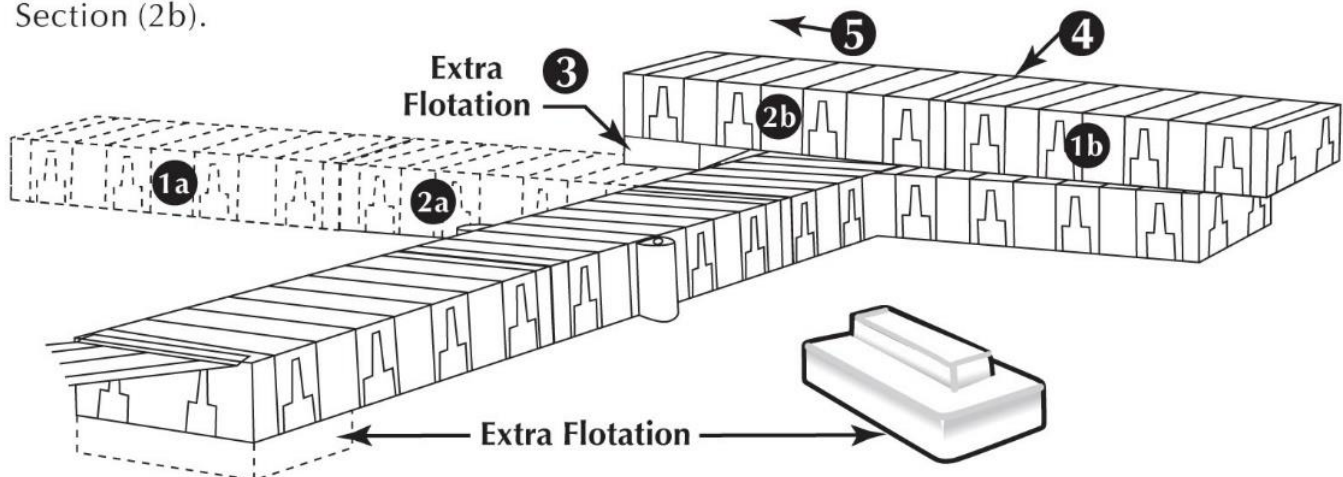

Instructions for:

Extra Flotation (EF2020)
2 or more people are needed for installation

Step 4

Reattach Float Section (1b) to (2b) with Float Connectors (**hand tighten only**).

Step 5

Place Float Section (1b & 2b) into the water and reattach to the main dock section. Tighten all bolts in the dock using 25 lbs/ft (3.46 kg/m) of torque. Anchor as desired.

NOTE: DO NOT SUBMERGE... a minimum of 3" (7.62 cm) must show above the water surface for venting purposes.

Recommendation

Use 2000 Series Extra Flotation to add 300 lbs (136.08 kg) of buoyancy and stability to your floating docks and where excessive weight is placed. Examples: Under heavy gangway or storage boxes.

Note: Check all bolts every three months or as needed to insure all connector hardware is securely fastened.



1501 Owner Avenue, Atlantic, IA 50022 USA
ventas@lobineando.com / info@lobineando.com

2000 Series (HP) Extra Flotation

www.connectadock.com

www.lobineando.com

The amount of weight being placed on to the dock will determine the number of Extra Flotations that will be needed. Position as follows:

Instructions for: _____

Extra Flotation (EF2020)

2 or more people are needed for installation

Bottom View of 2096 Float Section

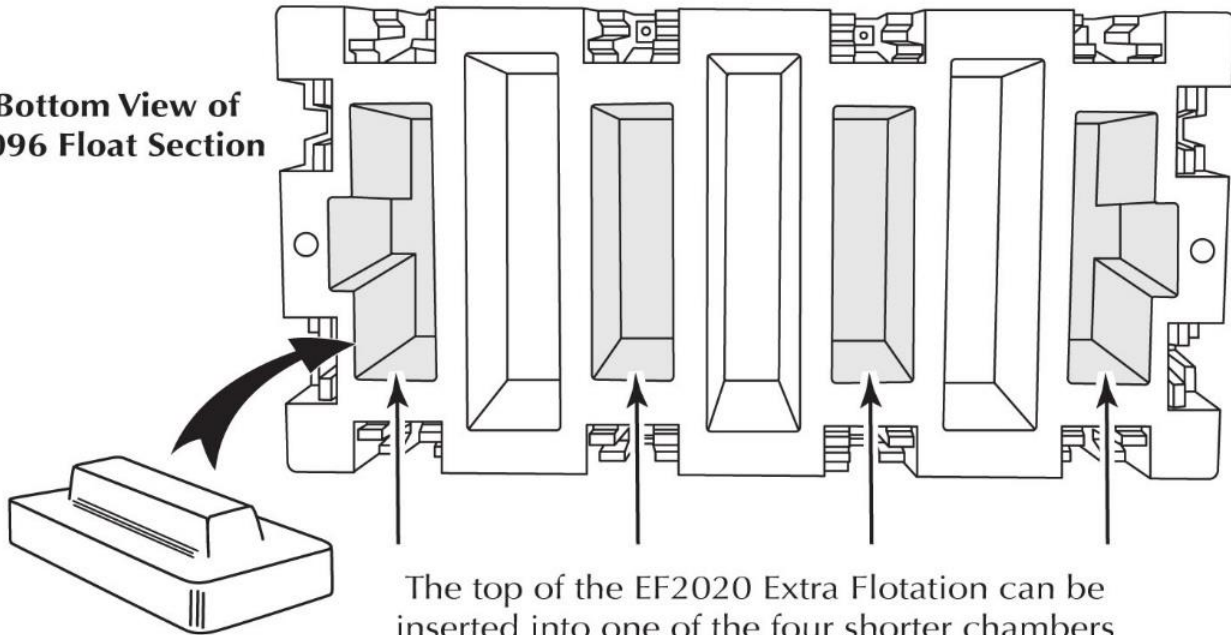

**EF2020
Extra Flotation**

The top of the EF2020 Extra Flotation can be inserted into one of the four shorter chambers on the bottom of the FS2096 Float Section (FS2024 Float Section has one chamber).

Side View of 2096 Float Section with Extra Flotation

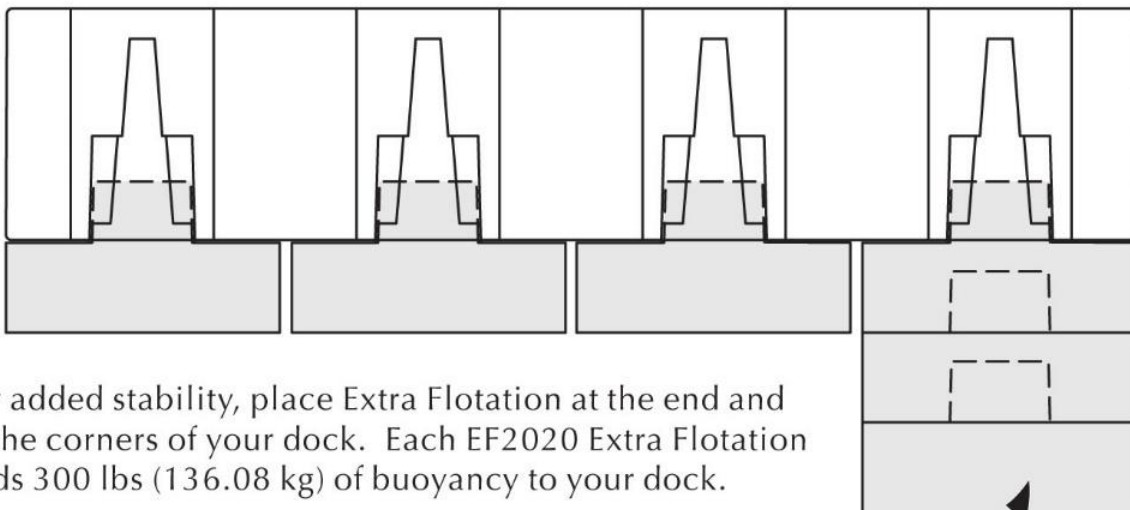

For added stability, place Extra Flotation at the end and at the corners of your dock. Each EF2020 Extra Flotation adds 300 lbs (136.08 kg) of buoyancy to your dock.

Extra Flotation can be stacked into another Extra Flotation when more buoyancy is needed.



1501 Owner Avenue, Atlantic, IA 50022 USA

ventas@lobineando.com / info@lobineando.com



layout and location of your utility channel.

Hardware Included

3/8" x 1-1/4" (10 mm x 35 mm)

Hex bolts

Diamond washers

Bushings



Step 1

Install Float Connectors into all Float Section sockets where Utility Channel Sections will be attached. Secure Float Connectors into sockets with bolts, washers, and bushings provided (**hand tighten only**).

Step 2

Female end of Utility Channel points in direction adding sections. Add Utility Channel by placing it over the Float Connectors, shift your body weight to the Utility Channel and hook into place. Secure with bolts, washers, and bushings. (**hand tighten only**) Secure with bolts, washers, and bushings. Remove lid and set aside. Continue adding Utility Channel floats.

Step 3

Tighten all bolts in the dock using 25 lbs/ft (3.46 kg/m) of torque. Anchor as desired. **NOTE: DO NOT SUBMERGE...** a minimum of 3" (7.62 cm) must show above the water surface for venting purposes.

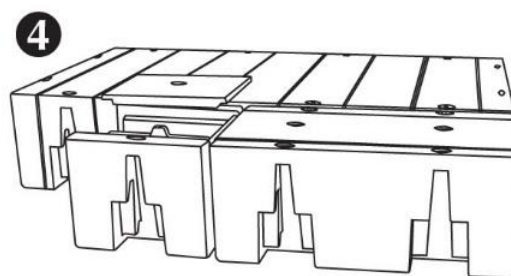
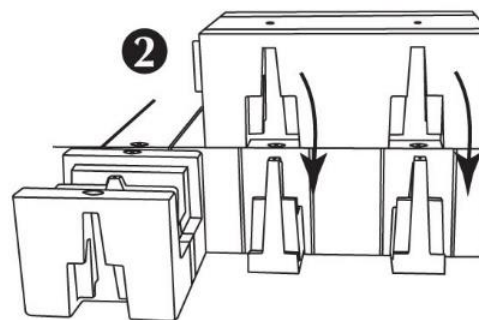
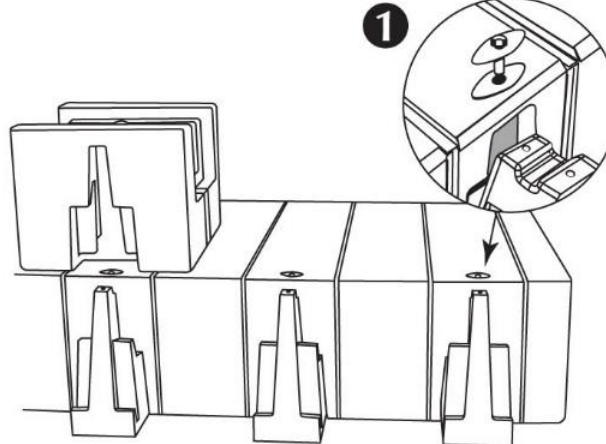

Step 4

Insert lid starting with last Utility Channel placed. Tighten per Step 3

FOR SAFE INSTALLATION AND OPERATION - All utilities conduit needs to meet all state and local utilities construction codes

Note: Check all bolts every three months or as needed to insure all connector hardware is securely fastened.



1501 Owner Avenue, Atlantic, IA 50022 USA
ventas@lobineando.com / info@lobineando.com

2000 Series Utility Channel End Cap

www.connectadock.com

www.lobineando.com

Tools Needed

Drill - 1/8" (3 mm) drill bit
Awl
Phillips Screw driver

Materials Needed

4- #8 Truss head 3/4" (4.2mm x 1.4mm x 20mm) (Stainless Steel)
Silcon



Step 1

Place End Cap into the Utility Channel with wide side at the top. End Cap placed on male end chaffer side out and female end chaffer side in. Use an awl to mark hole locations. Remove End Cap.

Step 2

Drill the holes with 1/8" (3 mm) bit.

Step 3

Place End Cap back into the Utility Channel. Then coat the Truss head screws with some silcon. Hand tighten the screws. (**Don't over tighten will strip the holes**).

Instructions for:

Utility Channel (UT2024),
(UT2048), (UTC2048)

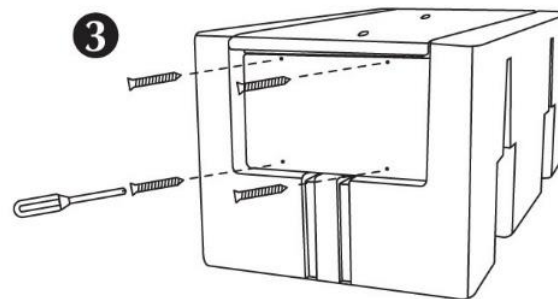
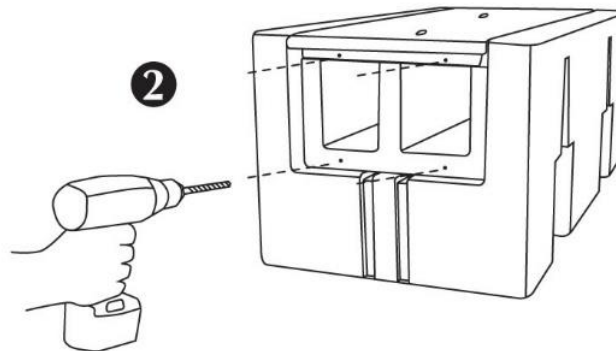
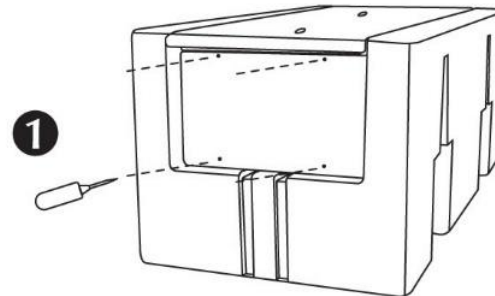

Note: The bottom two Screws are optional, if the lid will be removed frequently.



1501 Owner Avenue, Atlantic, IA 50022 USA

ventas@lobineando.com / info@lobineando.com



2000 Series Pedestal Lighthouse

www.connectadock.com

www.lobineando.com

Tools Needed

9/16" (16 mm) Socket wrench
3/8" (9.5 mm) Drill Bit and Drill

Before you begin: Determine the layout and location of your utility channel and Pedestal Lighthouse.
Note: Power Pedestal needs to be mounted between lid bolt points and not overlapping Utility Channel sections. NOTE: Power Pedestal hook up instructions included with Pedestal Lighthouse.

Step 1

Remove lid of Utility Channel and turn upside down.

Step 2

(a) Center metal bracket on Utility Channel Lid. (b) Mark and drill four corner holes all the thru the lid. (c) Dotted line shows area that could be cut to run utility lines to the power pedestal. Only cut a hole as large as needed.

Step 3

Secure Power Pedestal with carriage bolts, up thru Utility Channel Lid. Tighten all bolts in the dock using 25 lbs/ft (3.46 kg/m) of torque.

Step 4

Set Lid and Pedestal on top on the channel and Tighten all bolts in the dock using 25 lbs/ft (3.46 kg/m) of torque.

Instructions for:

Utility Channel (UT2048),
(UTC2048), Pedestal Lighthouse
(LH2000)

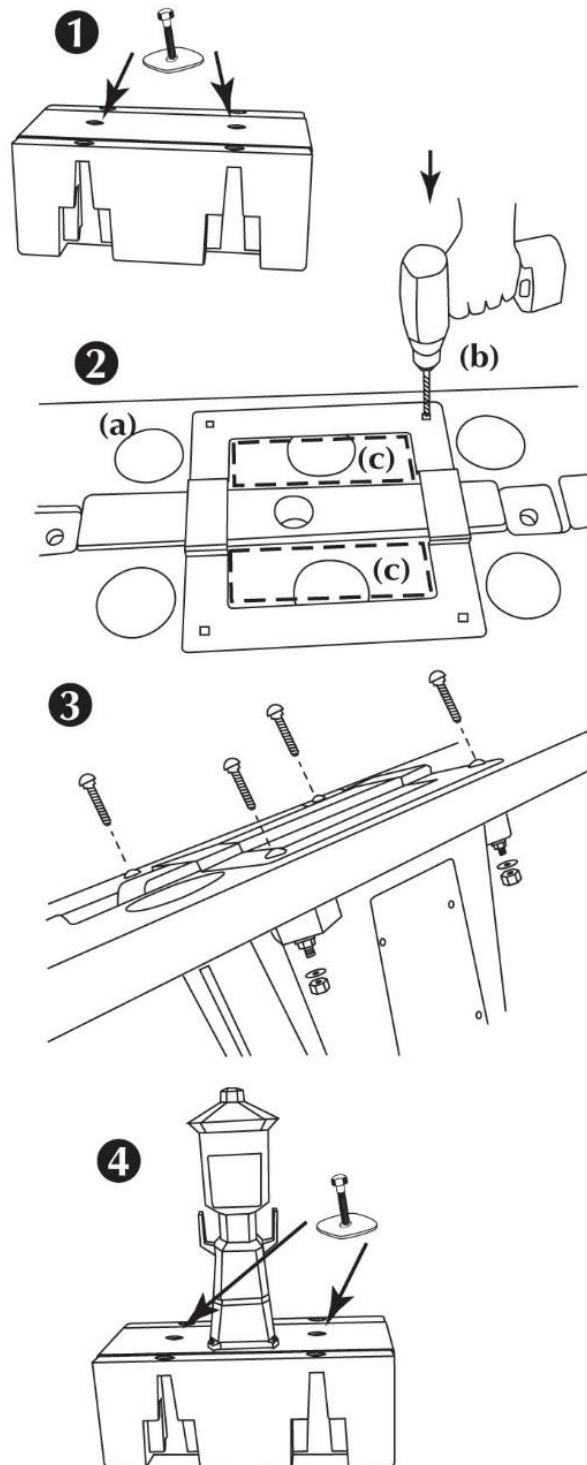

FOR SAFE INSTALLATION AND OPERATION - All utilities conduit needs to meet all state and local utilities construction codes



1501 Owner Avenue, Atlantic, IA 50022 USA
ventas@lobineando.com / info@lobineando.com

Tools Needed

3/4" Socket wrench
 5/8" Wrench or Socket wrench
Not available in metric

Items Included

(1) Gangway Frame
 (1, 2 or 3) Decking Panel(s)
 (1) Hinge
 (2) 1/2" x 2-1/2" Carriage bolts
 (2) 7/16" x 2 3/4" Hex bolts
 (2) 1/2" Nuts
 (2) 7/16" Nylock nuts
 (2) 1/2" Flat washers
 (2) 7/16" Flat washers

Step 1

Place Hinge on Float Section and line up Hinge holes with Float sockets. Secure Hinge to Float Section using Carriage bolts, Flat washers and Nuts.

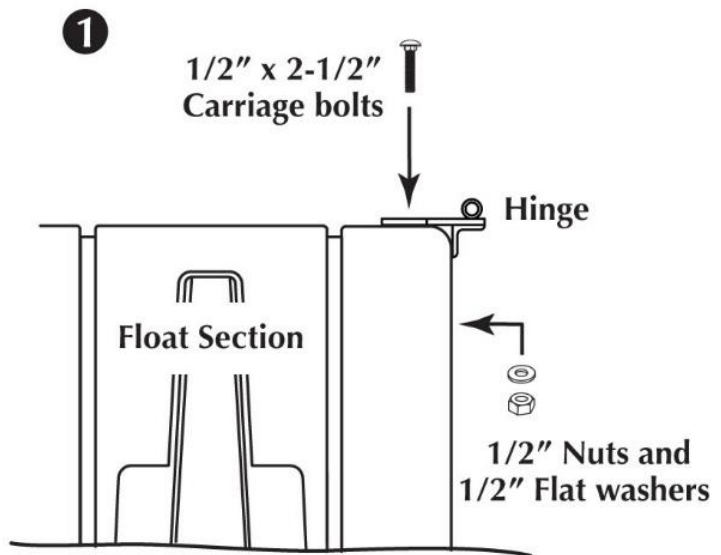
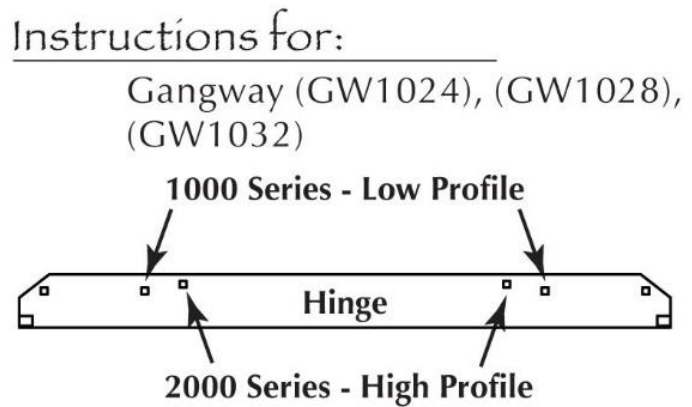

Step 2

Attach Gangway Frame to Hinge by lining up brackets with the holes on the sides of the Hinge. Insert Hex bolts with *end of bolt pointing outward* as shown. Secure with Flat washers and Nylock nuts using Socket wrench and wrench. *Note: If adding a Roller Kit-Install Rollers before Step 3.*

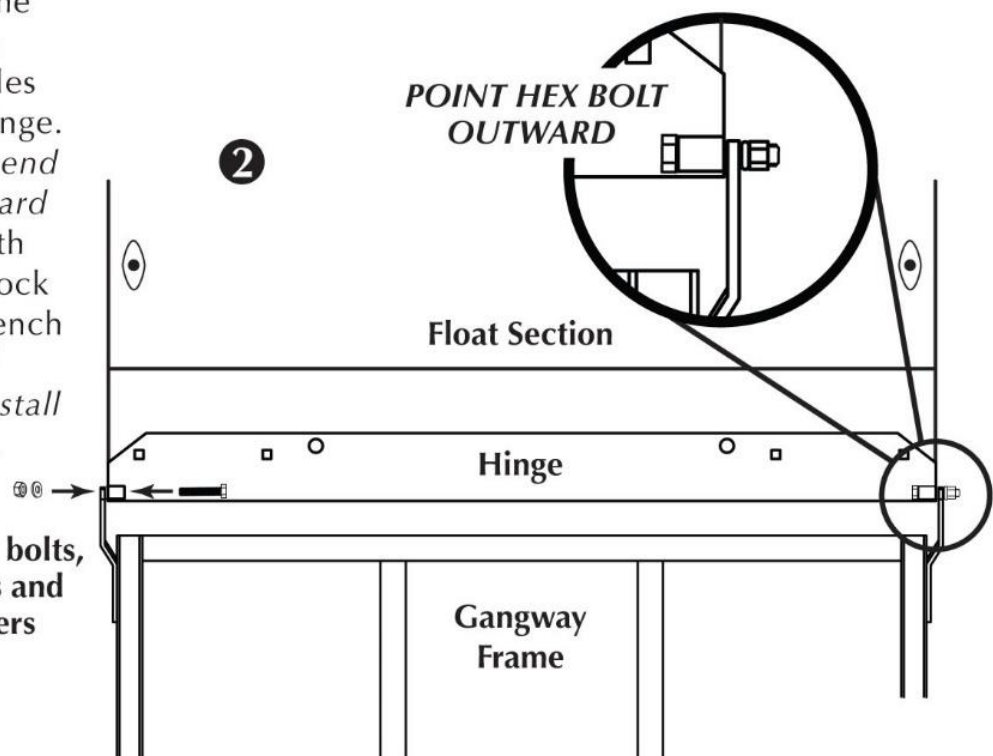

7/16" x 2 3/4" Hex bolts,
 7/16" Nylock nuts and
 7/16" Flat washers

Gangway

www.connectadock.com

www.lobineando.com

Step 3

With the notched end forward, position aluminum cross members on the back side of the Decking Panel inside the Gangway Frame.

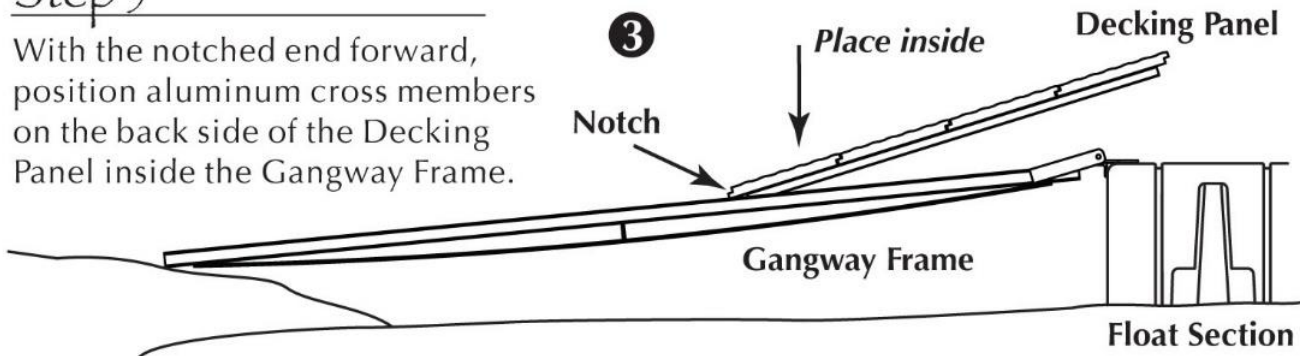

Step 4

Slide Decking Panel forward into place. Repeat with second Decking Panel for gangway GW1028.

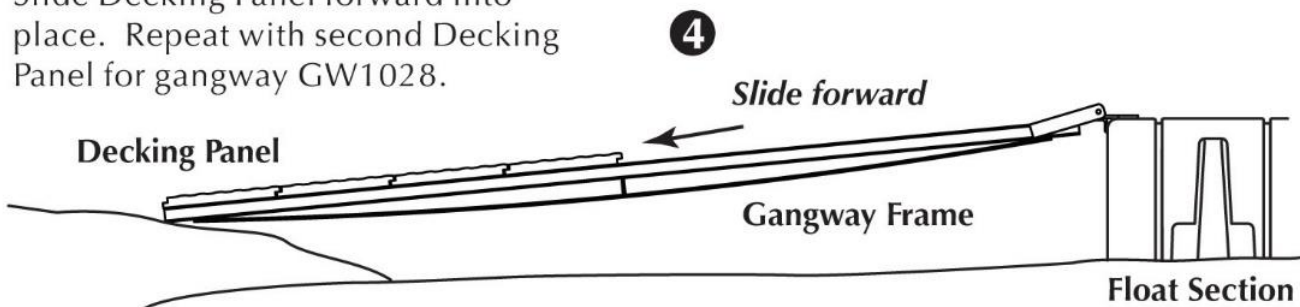

Step 5

Repeat Step 3 and Step 4 with second Decking Panel for gangway GW1028. Make sure the tip of the Second Decking Panel is under the lip of the First Decking Panel.

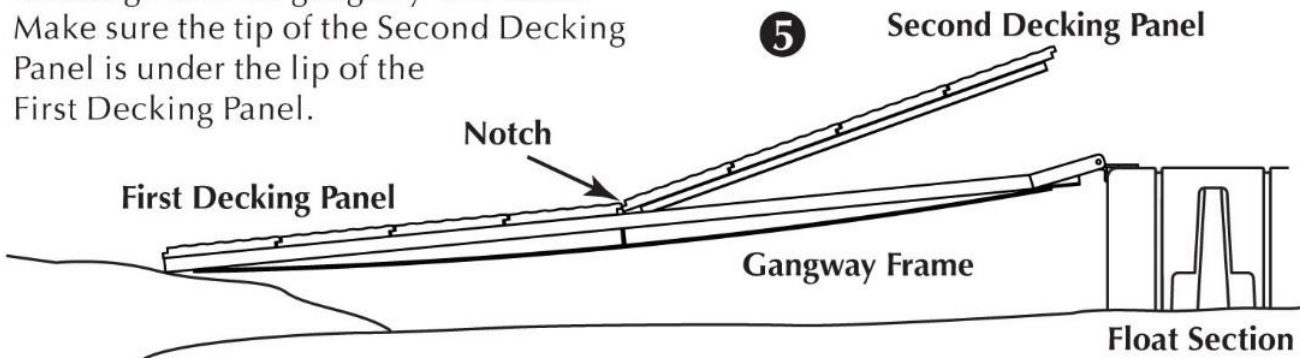

Assembled GW1024
4' x 4' Gangway
(1.2 m x 1.2 m)

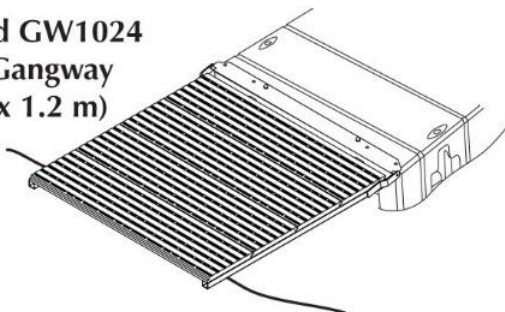

Assembled GW1028
4' x 8' Gangway
(1.2 m x 2.4 m)

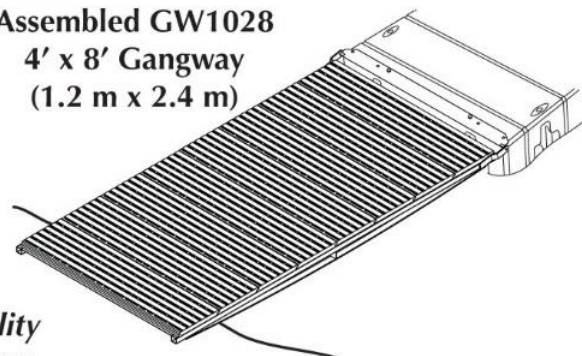

Recommendation: To add more buoyancy and stability with Gangway, use Extra Flotation under Float Section.

Note: Check all bolts every three months or as needed to insure all connector hardware is securely fastened.



1501 Owner Avenue, Atlantic, IA 50022 USA
ventas@lobineando.com / info@lobineando.com

Gangway Roller Kit

www.connectadock.com

www.lobineando.com

Tools Needed

9/16" Wrench or Socket wrench
Not available in metric

Items Included

- (4) 3/8" x 1-1/2" Hex bolts
- (4) 3/8" Nuts
- (4) 3/8" Washers
- (4) 3/8" Lock washers

Step 1

Set Gangway frame upside down on dock. Note: If Panels are on the Gangway Frame, remove before setting Frame upside down.

Step 2

Align Rollers to holes on the inside of the Frame. Attach with Bolt head and Washer on the outside of the Frame and the Lock Washer and nut on the inside. Continue to Gangway instruction Step 3 in add Panels.

Instructions for:

Roller Kit (RK1020)
Gangway (GW1024), (GW1028),
(GW1032)

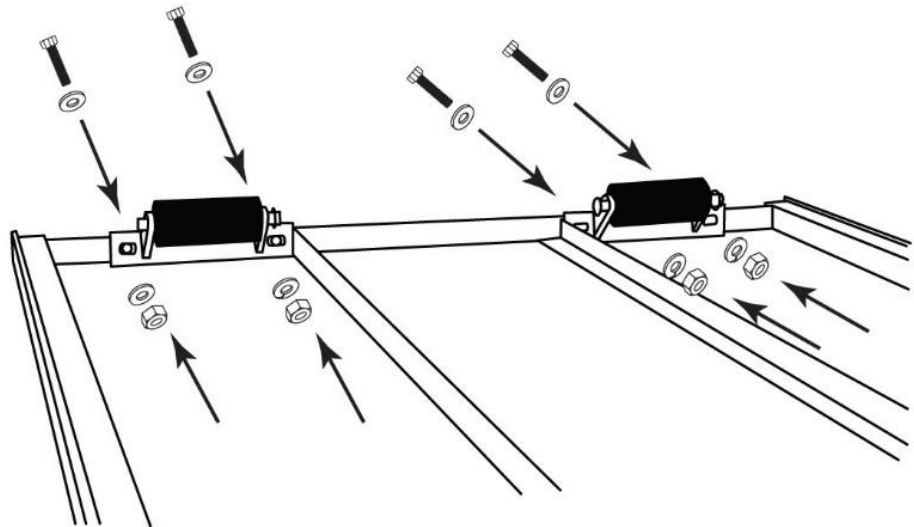

Gangway Hinge

www.connectadock.com

www.lobineando.com

Step 5

Turn gangway right side up; then place the Gangway Hinge on top deck of Float Section so square holes on Gangway Hinge match holes on Float Section.

Step 6

Secure Gangway Hinge to Float Section with 3 carriage bolts.

Step 7

Extra Flotation is recommended.
**See Extra Flotation instructions.*

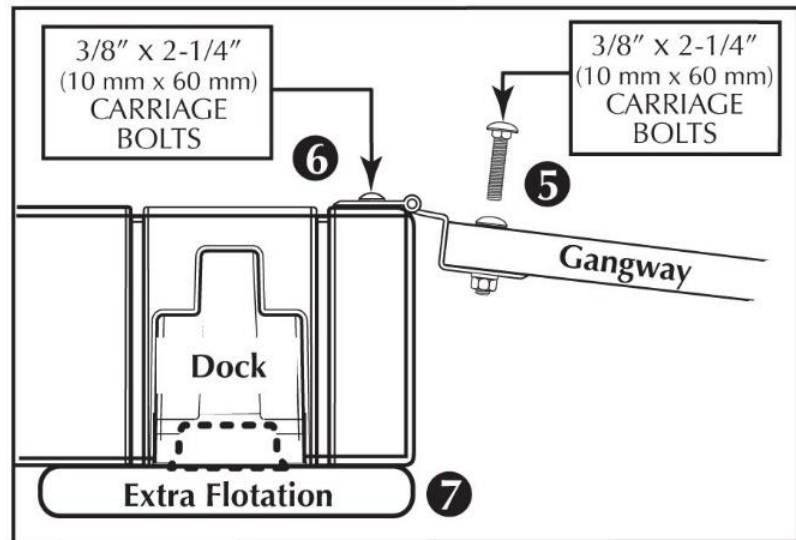

Gangway Roller Kit

www.connectadock.com

1-877-742-3071

Items Included

(1) Roller Kit (2 - rollers included)
Not available in metric

Materials Needed

(4) 3/8" x 4" Carriage bolts
(4) 3/8" Split lock washer
(4) 3/8" Hex nuts

Step 1

Place Rollers squarely on cross member of plank, drill bolt holes to match the oval roller holes. Use a hammer to insert four 4" carriage bolts from top side of gangway, secure from bottom with lock washers and nuts. **Don't over tighten.**

Step 2

Place Gangway Hinge on top deck of stationary platform. Secure gangway to stationary platform with long carriage bolts. (Note: Use 3 carriage bolts.)

Instructions for:

Roller Kit (RK1020)

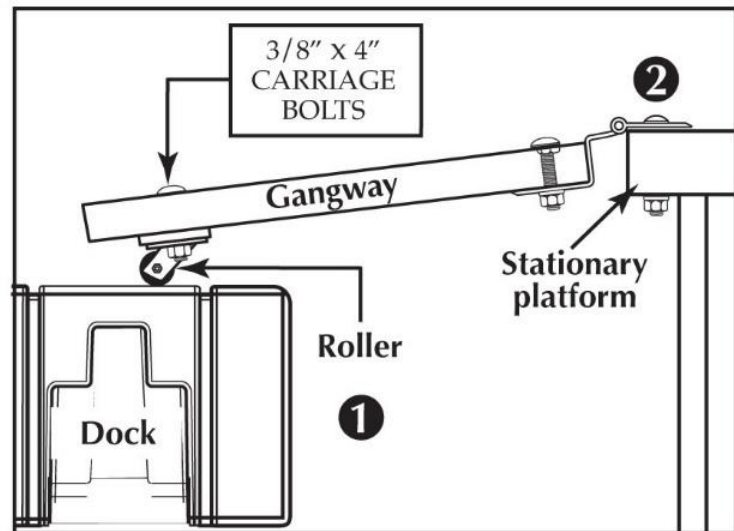

1501 Owner Avenue, Atlantic, IA 50022 USA

ventas@lobineando.com / info@lobineando.com



Gangway Hinge

www.connectadock.com

www.lobineando.com

Tools Needed

Hammer
9/16" (16 mm) socket wrench
Drill with 3/8" (10 mm) bit and
Phillips screw driver bit

Materials Needed

(40) 2" (5.08 cm) Steel deck screws
(4) 2" x 12" (5.08 cm x 30.48 cm) Planks
cut to length not exceeding 8' (2.4384 m)
(3) 1" x 4" (2.54 cm x 10.16 cm) Planks
cut to length for cross members

Items Included

(1) Gangway Hinge
(3) 3/8" x 2-1/4" (10 mm x 60 mm)
Stainless steel carriage bolts with
flat washers and lock nuts
(8) 3/8" x 2-1/4" (10 mm x 60 mm)
Stainless steel carriage bolts with
lock washers and nuts

Step 1

Place four planks side by side.

Step 2

Place cross members at lower edge
and center.

Step 3

Screw cross members to planks
with steel deck screws, as shown.

Step 4

Place Gangway Hinge across top end
of planks, drill bolt holes to match the
round hinge holes. Use a hammer to
insert eight of the carriage bolts from
top side of gangway, secure from
bottom with lock washers and nuts.
Don't over-tighten.

Instructions for:

Gangway Hinge (GH1020),
(GH2010), (GH2010M)

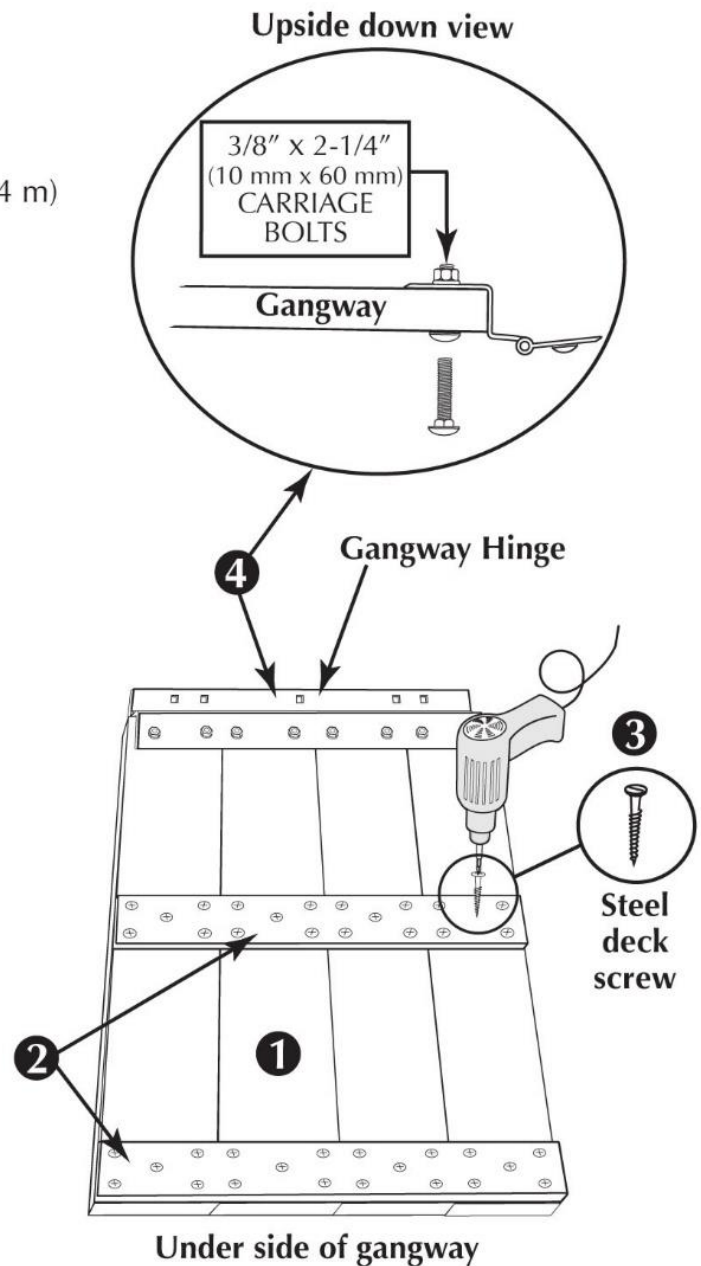

Note: Check all bolts every three months or
as needed to insure all connector
hardware is securely fastened.

Please use safety glasses while building the gangway.



1501 Owner Avenue, Atlantic, IA 50022 USA

ventas@lobineando.com / info@lobineando.com



Swim Ladder

www.connectadock.com

www.lobineando.com

Tools Needed

3/8" Socket wrench (16 mm) (2000 Series)

Hardware Included

Both 1000 Series & 2000 Series hardware is included

1000 Series—Low Profile

- (2) 1000 Series Finishing Connectors
- (2) 3/8" x 1-3/4" (10 mm x 44.45 mm) cap bolts
- (2) Round washers
- (2) Bushings
- (1) Allen wrench



2000 Series—High Profile

- (2) 2000 Versatile Connectors
- (2) 3/8" x 1-1/4" (10 mm x 35 mm) Hex bolts
- (2) Round washers



Warning: Swim Ladder does not float—tether to dock before beginning installation.

Step 1

With the Swim Ladder in an upright position, place the bracket portion of the Swim Ladder on an outer edge of the Float Section (as shown). Align the holes in the bracket with the holes in the Float Section.

Step 2

Holding the Swim Ladder in place, insert bushings and 1000 Series Finishing Connectors or 2000 Versatile Connectors into the two corresponding Float Section sockets.

Step 3

Insert bolts and washers into appropriate holes on each side of the Swim Ladder bracket. Tighten with allen wrench or socket wrench.

Step 4

Slide adjustable steps of Swim Ladder down into water and hook the bottom of step on depth stop to achieve desired length. (Note: The catch at the bottom of Swim Ladder will keep adjustable steps from dropping off into water.)

Instructions for:

Swim Ladder (SL1020), (SL1020M)

1000 Finishing Connector (FC1000), (FC1000M)

2000 Versatile Connector (VC2000), (VC2000M)

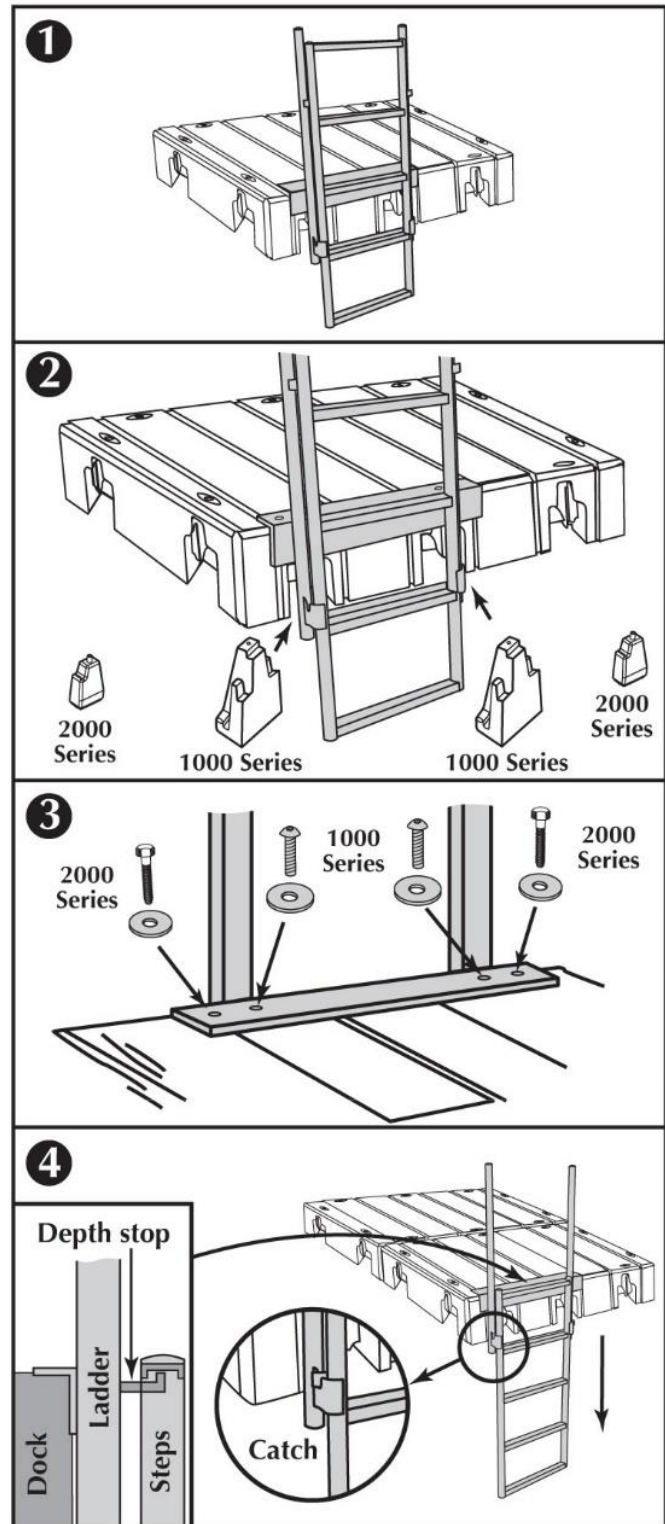

Recommendation: To add more stability at the Swim Ladder, use Extra Flotation under Float Section.

Note: Check all bolts every three months or as needed to insure all connector hardware is securely fastened.



1501 Owner Avenue, Atlantic, IA 50022 USA

ventas@lobineando.com / info@lobineando.com

Cleat

www.connectadock.com

www.lobineando.com

Tools Needed

1/2" (16 mm) Wrench or socket and ratchet

Hardware Included

5/16" x 1-1/2" Carriage bolt
(10 mm x 35 mm Hex bolt)
5/16" Stainless steel nylon lock nut
(10 mm Stainless steel nylon nut fastener)
3/8" (10 mm) Washer
Bushing

Step 1

Attach cleat at any Float Section socket. Insert bolt through Cleat and top of Float Section socket. From inside the socket, place bushing and washer on bolt and screw on lock nut.

Instructions for:

Cleat (8C1020), (8C1020M)

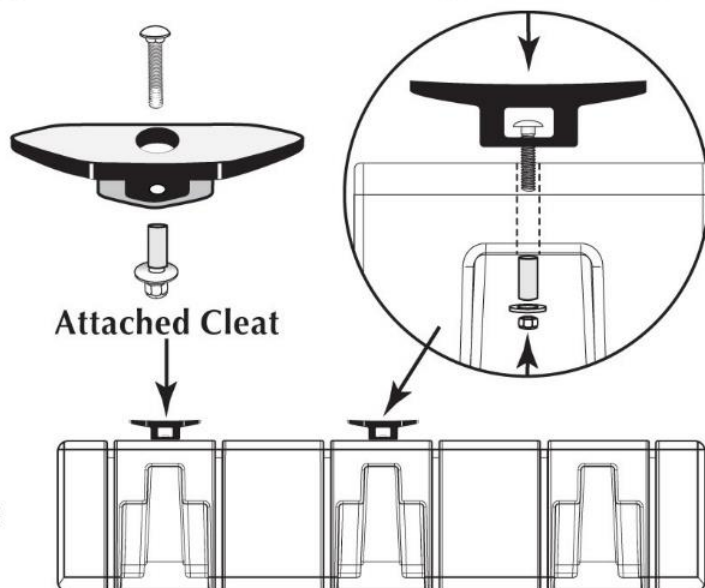

Note: To avoid losing hardware into water, install while on shore.

Finishing & Accessory Connectors

www.connectadock.com

1-877-742-3071

Tools Needed

9/16" (16 mm) Socket wrench

Hardware Included

3/8" x 1-1/4" (10mm x 35 mm) Hex bolt
Hex bolt
Diamond washer
Bushing

Step 1

Install Finishing or Accessory Connectors into sockets where needed. Secure Connectors into sockets from top with bolts, washers, and bushings as shown. Tighten 1000 and 2000 Series Connectors to 25 lbs/ft (3.46 kg/m) of torque.

Instructions for:

Finishing Connector (FC1000),
(FC1000M), (FC2000), (FC2000M)
Accessory Connector (AC1000),
(AC1000M), (AC2000), (AC2000M)

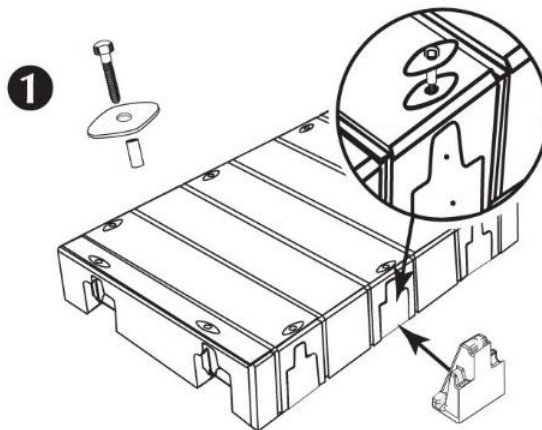

Use Accessory Connectors to attach functional accessories to your floating dock.

Note: Check all bolts every three months or as needed to insure all connector hardware is securely fastened.

1501 Owner Avenue, Atlantic, IA 50022 USA

ventas@lobineando.com / info@lobineando.com



2000 Series (HP) Guardrail

www.connectadock.com

www.lobineando.com

Tools Needed

9/16" Socket wrench
Not available in metric

Hardware Included

(2) 2000 Series (HP) Accessory Connectors
(2) 3/8" x 3/4" Hex bolt
(2) 3/8" Diamond washers

Step 1

Using hex bolts and washers, attach both 2000 Series (HP) Accessory Connectors to Guardrail as shown.

Step 2

Install 2000 Series (HP) Accessory Connectors with attached Guardrail into sockets where needed.

Step 3

Secure 2000 Series (HP) Accessory Connectors into sockets from top with bolts, washers, and bushings as shown. Tighten 2000 Series (HP) Accessory Connectors to 25 lbs/ft (3.46 kg/m) of torque.

Instructions for:

Guardrails (GR2044BR),
(GR2067BR), (GR2067LPBR),
(GR2092BR), (GR2092FSBR)
2 or more people are needed for installation

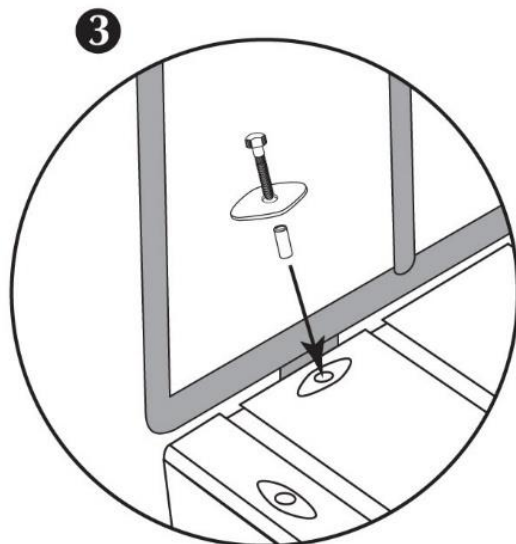
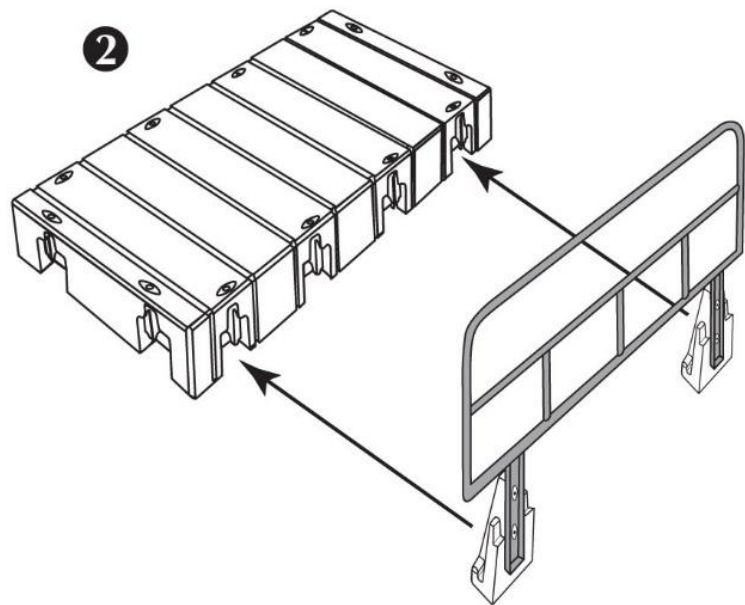
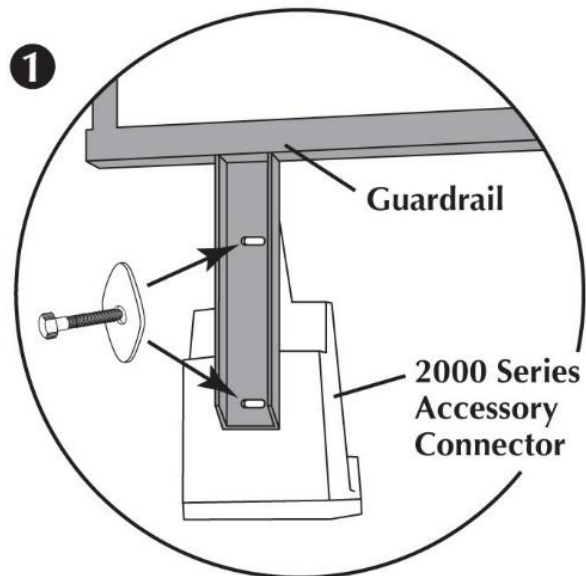

Recommendation: To add more buoyancy and stability with Guardrail, use Extra Flotation under Float Section.

Note: Check all bolts every three months or as needed to insure all connector hardware is securely fastened.



1501 Owner Avenue, Atlantic, IA 50022 USA

ventas@lobineando.com / info@lobineando.com



Self Wicking Planter & Pole Connector





www.connectadock.com

www.lobineando.com

Tools Needed

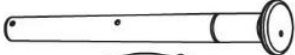
9/16" (16 mm) Socket wrench

Hardware Included

Wicking Post 
Rope wick 
Black retaining washer 
Hinge pin 

Step 1

Insert Wicking Post thru Planter from the top, making sure that it is fully seated in the bottom of the pot.

Step 2

The rope wick has a long end and a short end, relative to the knot. Insert the short end of rope down thru the Planter/Wicking Post assembly thru the hole provided in the Wicking Post. The rope wick should slightly protrude from the bottom of the Wicking Post with the knot resting at the bottom of the Planter.

Step 3

Insert Wicking Post through the Pole Connector.

Step 4

Slide the black retaining washer over the Wicking Post up to the bottom of the Pole Connector. Insert hinge pin through hole in Wicking Post. **Note: If your rope wick becomes unraveled and frayed at the ends, don't be concerned, it will still function as intended.**

Step 5

Install Pole Connector into socket where needed. Secure Pole Connector into socket from top with bolts, washers, and bushings as shown. Tighten 1000 and 2000 Series Pole Connectors to 25 lbs/ft (3.46 kg/m) of torque.

Instructions for:

Self Wicking Planter (SWP1020)
1000 Pole Connector (PC1010),
(PC1010M)
2000 Pole Connector (PC2022),
(PC2022M)

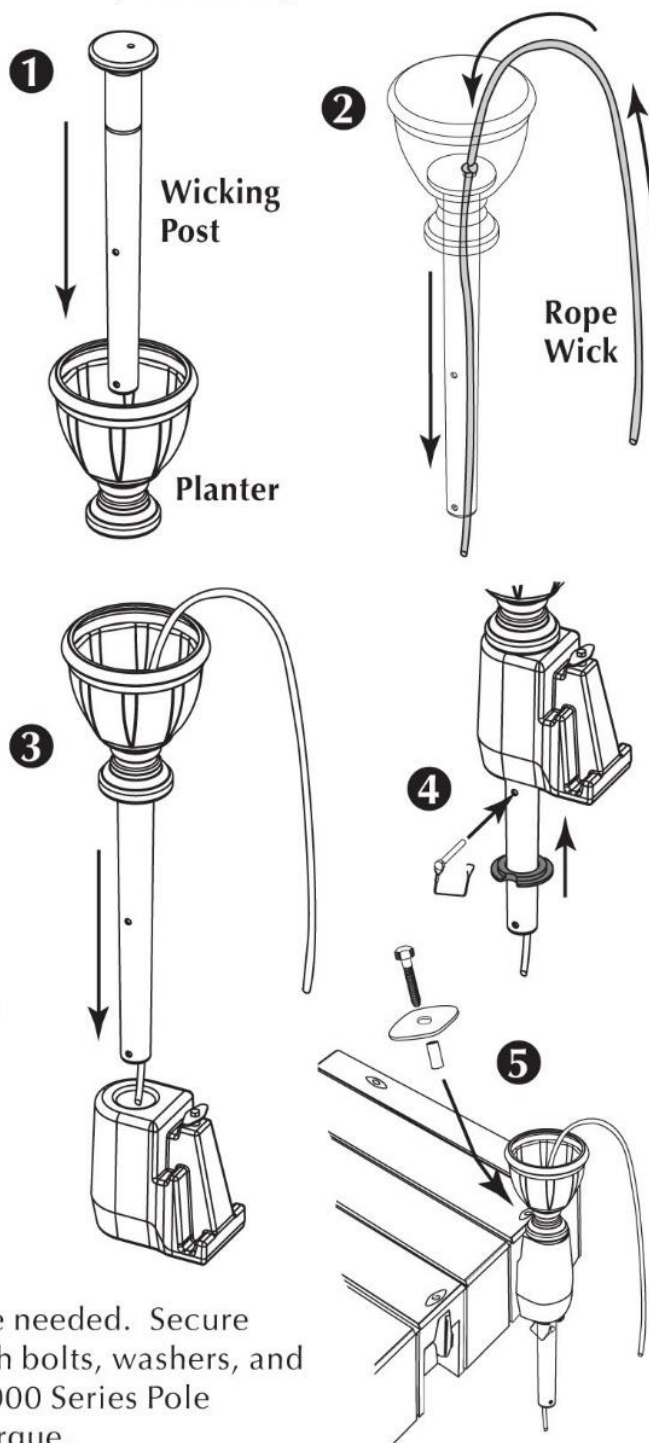

Self Wicking Planter

www.connectadock.com

www.lobineando.com

With your Planter assembly attached to your dock, you are now ready to fill your Planter with your favorite plants.

Step 6

While filling the Planter with potting soil, coil the rope wick up thru the soil along the sides of the pot. **Note: The rope wick should never be exposed above the soil as this will cause it to dry out. We recommend the last coil to be at least 1" (2.5 cm) below the soil's surface.**

Step 7

Add plants to Planter following the recommended planting instructions.

Step 8

Jump start the wicking system by flooding the Planter with water. The excess water will drain out thru the bottom of the Planter and the rope wick. After the excess water has drained, the rope wick will always provide the correct amount of moisture for plants to thrive.

Note: Although the soil may appear dry on the surface, the wicking system will always supply plants the moisture needed at the roots. Also, the wicking system will drain off the excessive water after a rain shower.

Instructions for:

Self Wicking Planter (SWP1020)
Adding plants to installed Planter

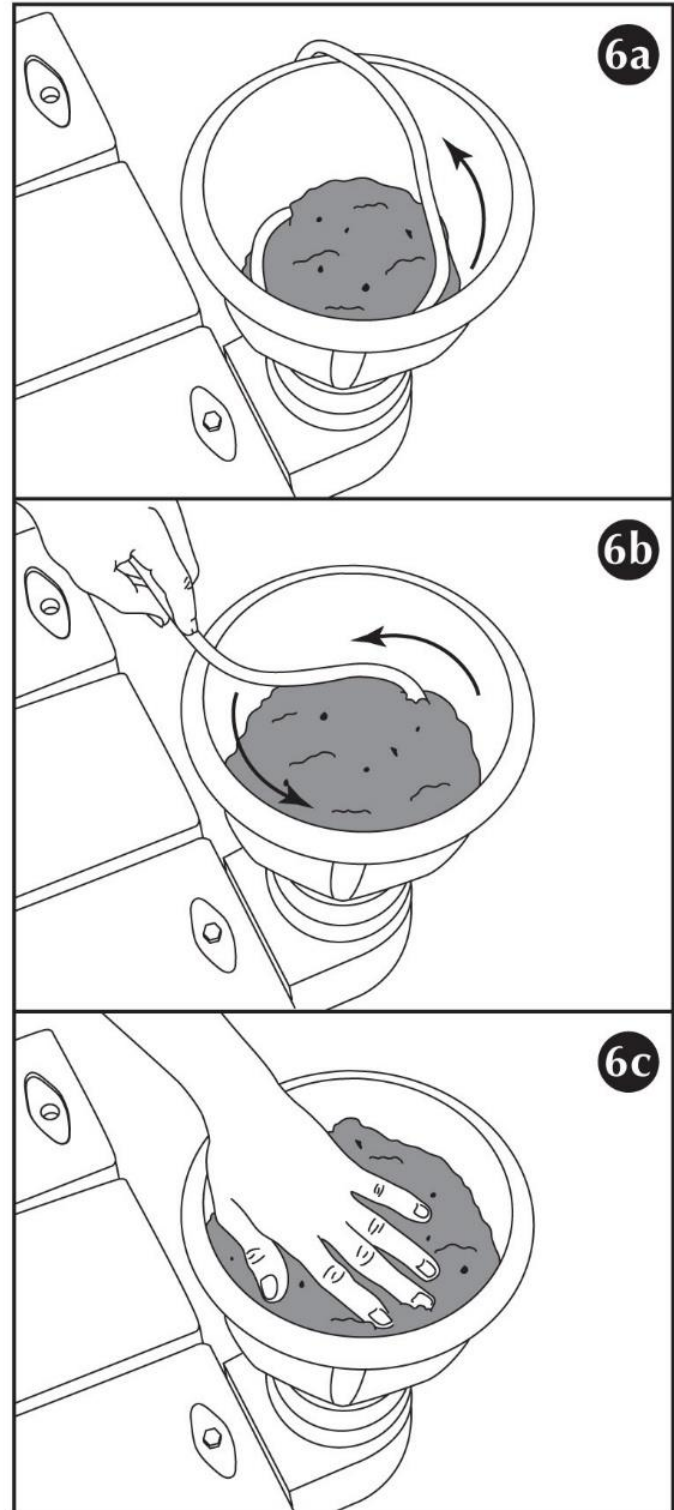

Note: Please exercise caution when using the planter in salt water environments. Check to make sure that the plants are salt water compatible before planting. If using in salt water, please check the wick for salt deposits and replace, if necessary.



1501 Owner Avenue, Atlantic, IA 50022 USA

ventas@lobineando.com / info@lobineando.com



2000 Series (HP) Bench & Armrests

www.connectadock.com

www.lobineando.com

Tools Needed

9/16" (16 mm) Socket wrench
Not available in metric

Hardware Included

Bench Hardware

- (4) 2000 Versatile Connectors
- (4) 3/8" x 3/4" Hex bolts
- (4) Diamond washers
- (4) 3/8" x 2-1/4" Hex bolts
- (4) Long bushings



Armrest Hardware

- (6) 3/8" x 1-1/4" Xylon coated bolt
- (6) 3/8" Split lock washer
- (6) 3/8" Flat washers
- (6) Short bushings

Instructions for:

- Bench & Armrests (BH2000)
- Bench (BH2020)
- Bench Armrests (BA2020)
- Bench Hardware Kit (BHK2000)

Step 1

Position Bench over sockets on a fully installed 2000 series dock.

Step 2

Insert the 2000 Versatile Connectors into the corresponding dock sockets. Secure 2000 Versatile Connectors into socket from top with bolts and washers as shown. Tighten to 25 lbs/ft (3.46 kg/m) of torque. If attaching to dock where Connectors are already located, remove the bolts in the top of the Connector and replace with 2-1/4" bolt and long bushing.

Note: A minimum of THREE (3) 2000 Versatile Connectors are required to securely attach bench to existing 2000 series dock system.

Step 3

Position the 3 holes of the left Bench Armrest with the 3 holes in the left side of the Bench. Secure with bolts, washers and short bushings. Install the right Bench Armrest using the same instructions.

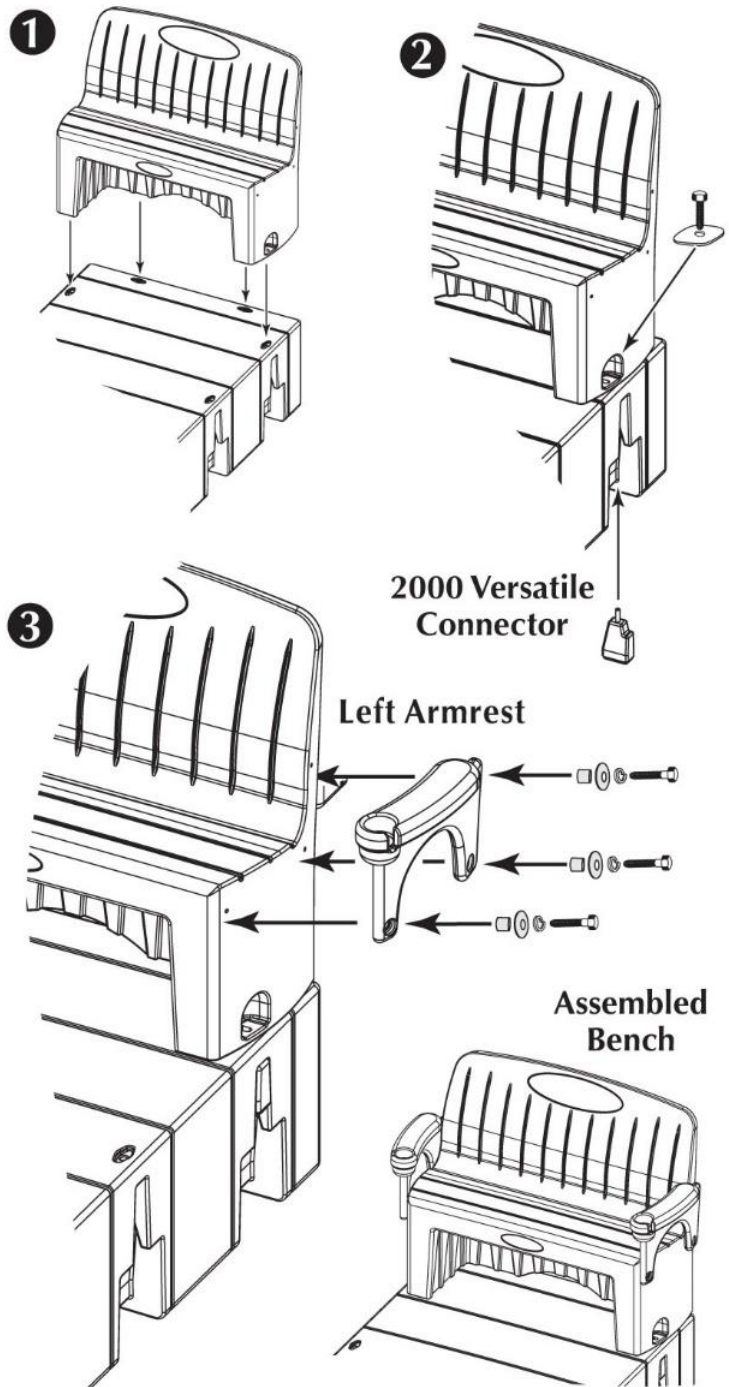

Note: Check all bolts every three months or as needed to insure all connector hardware is securely fastened.



1501 Owner Avenue, Atlantic, IA 50022 USA
ventas@lobineando.com / info@lobineando.com

2000 Series (HP) Flag Pole

www.connectadock.com

www.lobineando.com

Tools Needed

9/16" Socket wrench
Rubber mallet or hammer
Not available in metric

Hardware Included

(4) 3/8" x 1 1/4" Hex bolt & nut
(1) 3/8" x 3 1/2" Hex bolt & nut
(1) 3/8" x 2" Hex bolt
(1) 3/8" Diamond washers

Step 1

Insert Stop Bolt in the Pole Bracket.

Step 2

Drive white sleeve into Pole Sleeve with a block of wood until it touches the Stop Bolt

Step 3

Attach the Pole Sleeve with the Accessory Connector-metal with four bolts in outer holes.

Step 4

Insert Accessory Connector-metal into the float section socket with bolt, washers, and bushing. Tighten bolt to 25 lbs/ft (3.46 kg/m).

Step 5

Attach gold ornament top of telescoping flag pole.

Step 6

Insert Flag Pole into Pole Bracket.

Step 7

Raise and lower Telescoping Flag Pole and lock in place with Pin Lock release button.

Instructions for:

Accessory Connector-metal
(AC2022MTL), Pole Bracket
(PB2022), Flag Pole (FP2000)

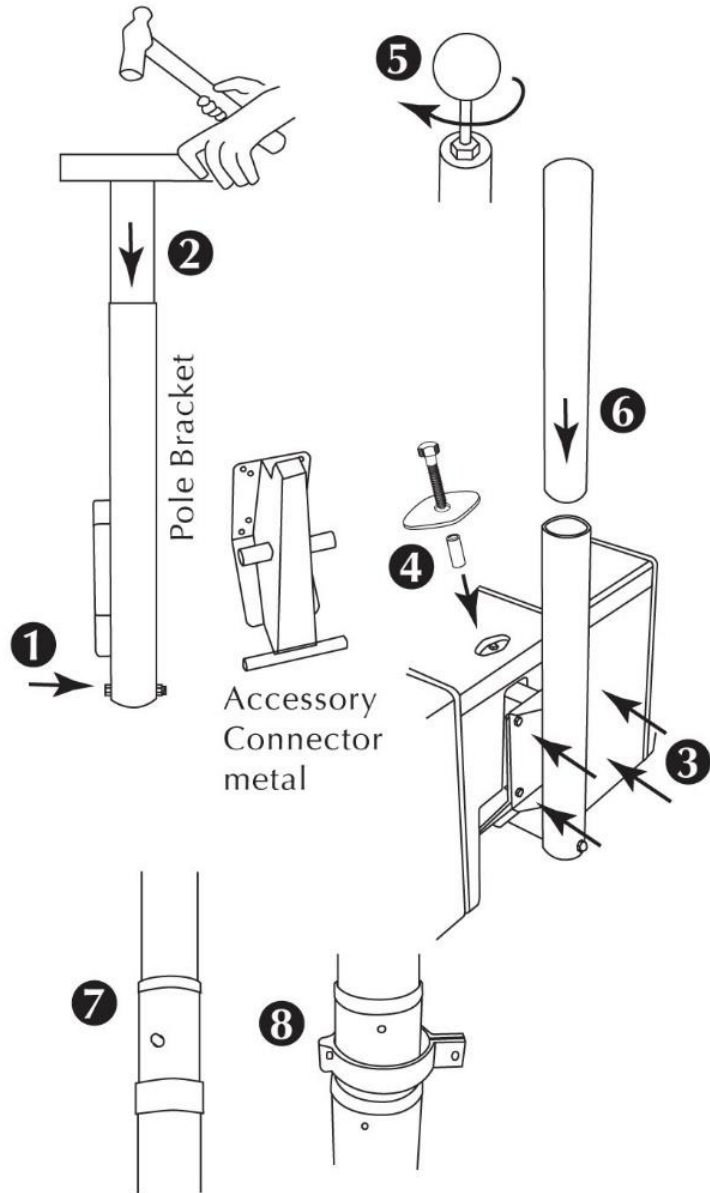

Step 8

Optional locking device around lowest release button and locks with nut & bolt or small padlock. This keeps anyone from lowering the pole.



1501 Owner Avenue, Atlantic, IA 50022 USA

ventas@lobineando.com / info@lobineando.com



1000 & 2000 Series Edge Bumper

www.connectadock.com

www.lobineando.com

Tools Needed

Drill - 1/8" (3.5 mm), 3/8" (9.5 mm) drill bit & 1" (25.5 mm) Wood bore bit
White or light color marker
9/16" (16 mm) Socket wrench
Saw

Materials Needed

4" x 3/8"-16 (10 cm x 10 mm) bolt, nut and washer -each hole drilled

Step 1

Determine location of Edge Bumper. Cut Edge Bumper at the end of Float Sections if needed. Align with Dock edge and mark hole locations up thru float connector sockets. Straight Edge Bumper as needed to align with dock edge.

Step 2

Drill the holes with 1/8" (3.5 mm) bit all the way thru the Edge Bumper.

Step 3

(A) Counter sink the holes with 1" (25.5 mm) Wood bore bit 1" (25.5 mm) deep on opposite side of hole location marks.

(B) Finish drilling holes with 3/8" (10 mm) bit all the way thru the Edge Bumper.

Step 4

Place Edge Bumper on dock section and bolt into place. Tighten all bolts in the Edge Bumper using 25 lbs/ft (3.46 kg/m) of torque.

Instructions for:

Edge Bumper (EB1020)

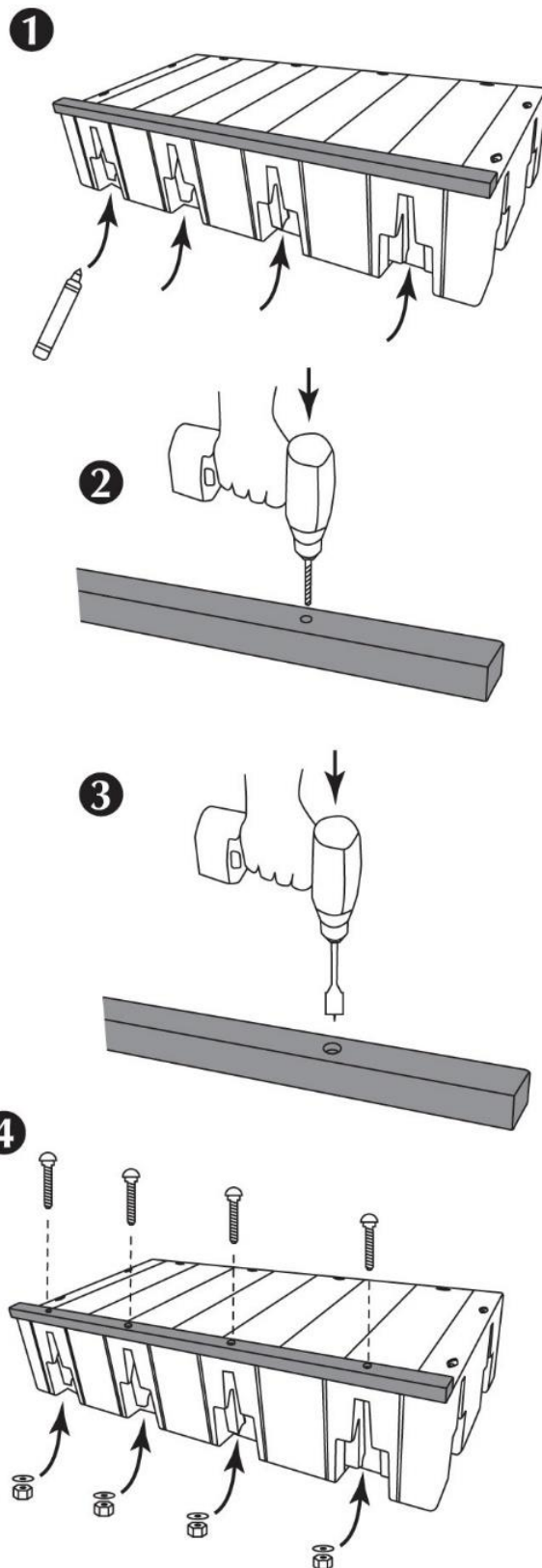

Pole Pounder & Pole Connector

www.connectadock.com

www.lobineando.com

Tools Needed

9/16" (16 mm) Socket wrench

Step 1

Determine the length of poles needed. Start with long poles and either drive further down or cut off tops after driving. Leave extra length above top of dock at high water elevation.

Step 2

Slip the Pole Connector over the top of the pole. Attach the Pole Connector to the dock in the desired location. Secure Pole Connectors into sockets with bolts, washers, and bushings as shown. Tighten the bolts using 25 lbs/ft (3.46 kg/m) of torque.

Step 3

Slip the open end of the Pole Pounder over the top of the pole. Grab each of the handles and raise the Pole Pounder up without clearing the top of the pole. Strike down on the top of the pole, and continue striking the pole until the predetermined depth is reached. Pound almost to refusal.

Step 4

Cover those unsightly 2" (5.08 cm) anchor pole tops by slipping the Pole Cover over the top of the pole.

Instructions for:

Pole Pounder (PP1002)
1000 Pole Connector (PC1010),
(PC1010M)
2000 Pole Connector (PC2022),
(PC2022M), (PC2023),
(PC2023M)
Pole Cover (PC1002)

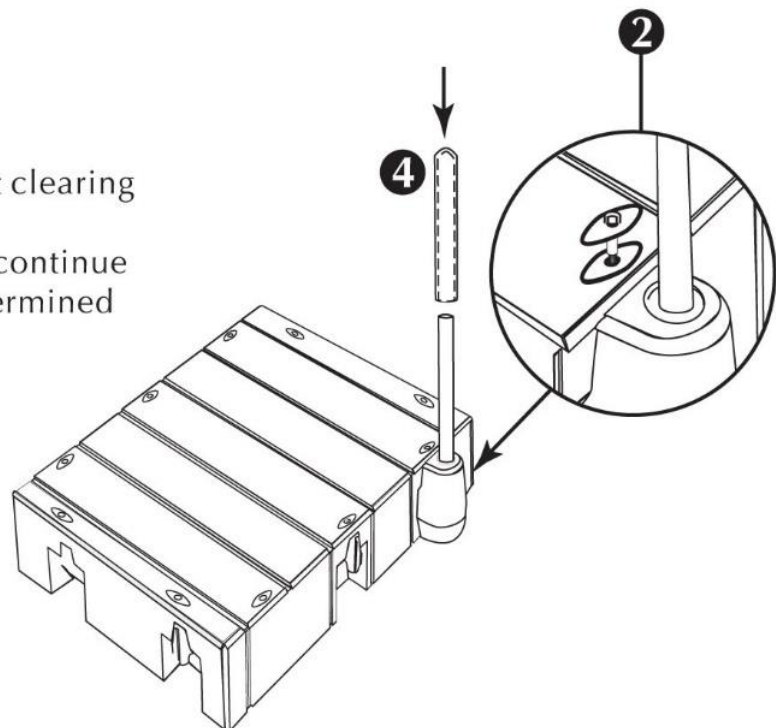
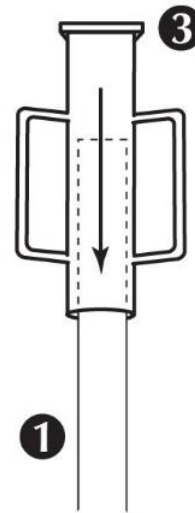

Note: Check all bolts every three months or as needed to insure all connector hardware is securely fastened.

1501 Owner Avenue, Atlantic, IA 50022 USA

ventas@lobineando.com / info@lobineando.com



Pole Remover

www.connectadock.com

www.lobineando.com

Note

See T-Post Puller instruction for handle installation.

Recommendation

Two people make removing the poles easier.

Step 1

Remove pole sleeve.

Step 2

Wrap cable around pole 2 to 3 times and over lapping the cable at least ounce.

Step 3

Insert loop thru other loop to create slip knot.

Step 4

Insert the attachment loop over the puller point of the attachment as shown. *Note: Bolt doesn't have to be removed to attach cable loop.*

Step 5

Slide cable down on the pole and position puller handle in the up location to create tension on the cable.

Step 6

With cable tight push down on the handle.

Instructions for:

Pole Remover (PR1002)

Step 6

Repeat step 5 to 7 until pole is loose.

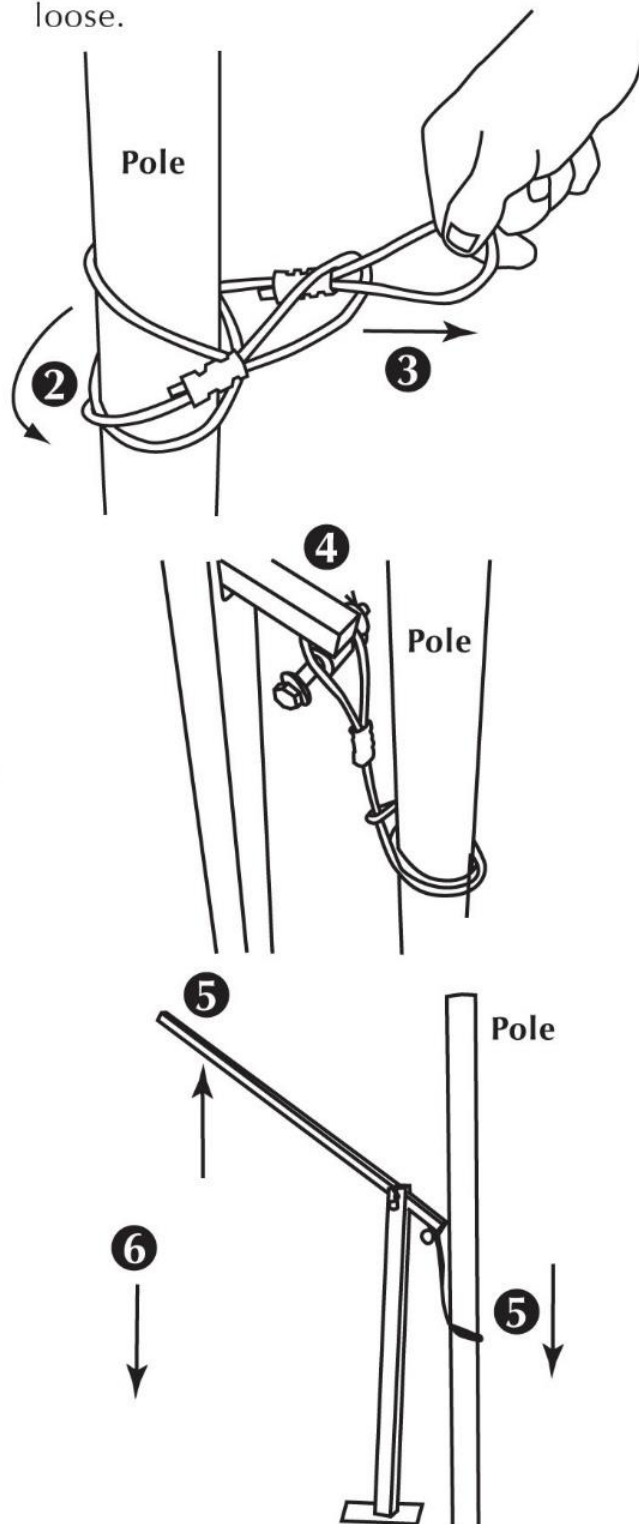

Pole Auger & Pole Connector

www.connectadock.com

www.lobineando.com

Tools Needed

Drill and 5/16" (8 mm) Oversized drill bit
9/16" (16 mm) Socket wrench
Dowel

Hardware Included

5/16"-18 x 3" Stainless steel hex screw
5/16" Stainless steel nylon lock nut
Not available in metric

Step 1

Determine the length of poles needed. Start with long poles and either drive further down or cut off tops after driving. Leave extra length above top of dock at high water elevation.

Step 2

Insert the shaft of the auger into the lower end of the pole. Drill a hole all the way through the bottom of the pole and the shaft of the auger. Insert the hex screw provided and tighten with lock nut. Next, drill a hole all the way through the top of the pole.

Step 3

Slip the Pole Connector over the top of the pole. Attach the Pole Connector to the dock in the desired location. Secure Pole Connectors into sockets with bolts, washers, and bushings as shown. Tighten the bolts using 25 lbs/ft (3.46 kg/m) of torque.

Instructions for:

Pole Auger (PA1002)
1000 Pole Connector (PC1010),
(PC1010M)
2000 Pole Connector (PC2022),
(PC2022M), (PC2023),
(PC2023M)
Pole Cover (PC1002)

Step 4

Insert a pin, dowel, or rod about 2' (60.96 cm) or longer into the previously drilled hole in the top of the pole. Turn clockwise to auger into the lake bed. To remove the pole, simply turn the pole counter clockwise.

Step 5

Cover those unsightly anchor pole tops by slipping the Pole Cover over the top of the pole.

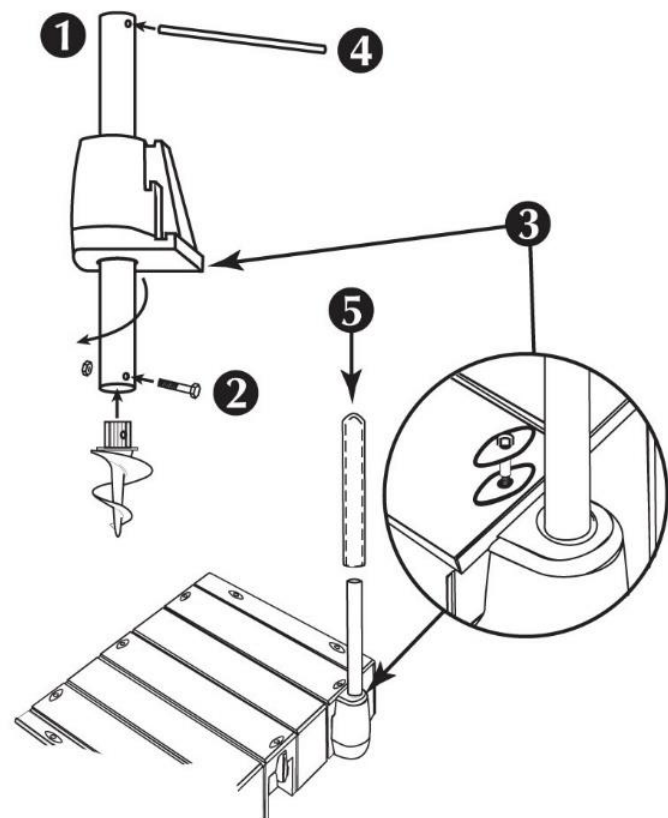

Note: Check all bolts every three months or as needed to insure all connector hardware is securely fastened.



1501 Owner Avenue, Atlantic, IA 50022 USA

ventas@lobineando.com / info@lobineando.com



Dead Man Collar

www.connectadock.com

www.lobineando.com

Tools Needed

9/16" (16 mm) Socket wrench
Small long rope for holding docks to shore.

Items Not Included

1/4" (6.35 mm) Chain
3/8" x 3"-4" (10 mm x 10 cm) Bolt
3/8" (10 mm) Lock nut
(2) 3/8" (10 mm) Washers

Step 1

Attach the Pole Connector to the dock in the desired location. Secure Pole Connectors into sockets with bolts, washers, and bushings as shown. Tighten the bolts using 25 lbs/ft (3.46 kg/m) of torque.

Step 2

Slip the long end of the Dead Man Collar into the Pole Connector.

Step 3

Insert a weighted chain through the bottom of the Dead Man Collar. (Note: Use a heavy gauge wire bent into a hook to reach through the Dead Man Collar to pull the chain up the center). Fasten the chain by setting a link in the groove in the top of the collar.

Instructions for:

2" Dead Man Collar (DM1002)
2" Dead Man Collar (DM2002)
1000 Pole Connector (PC1010)&M
2000 Pole Connector (PC2022)&M

Step 4

With the extra chain hanging down the side Pole Connector, put a bolt with a washer at its head through a link. Repeat adding links on to the bolt every few links to make a ball. Make the chain ball big enough so the chain can't pass through the Dead Man Collar. Add the washer and nut to hold chain ball in place.

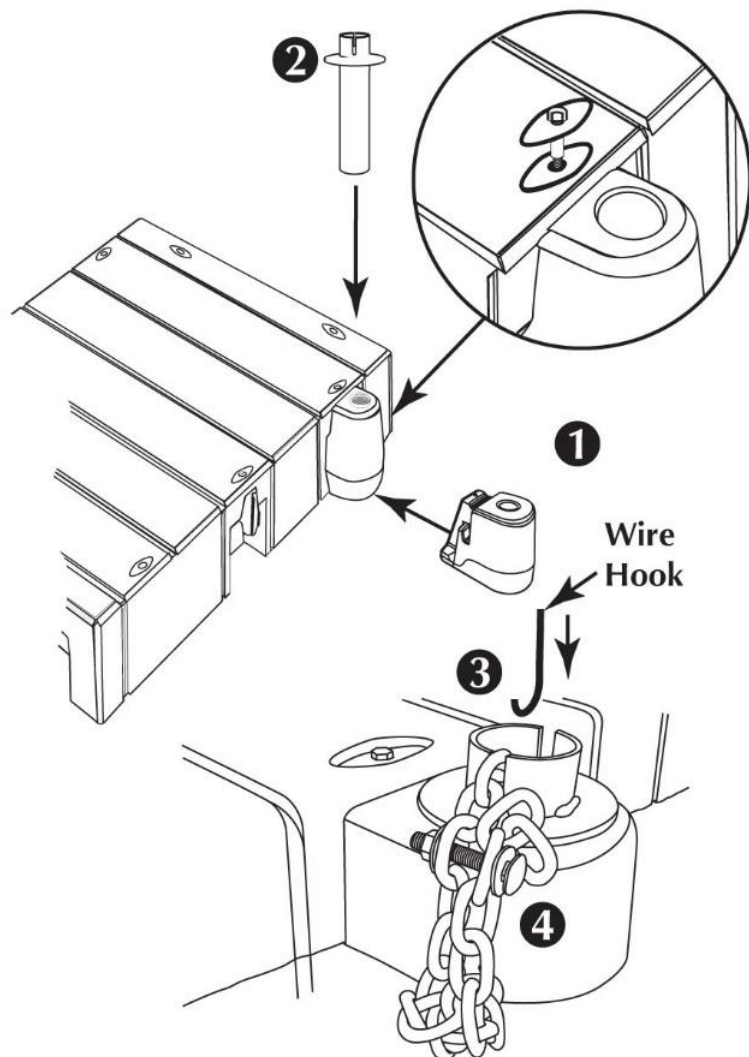

Note: Check all bolts every three months or as needed to insure all connector hardware is securely fastened.



1501 Owner Avenue, Atlantic, IA 50022 USA
ventas@lobineando.com / info@lobineando.com

Stiff Arm Fitting

www.connectadock.com

www.lobineando.com

Tools Needed

- 1/2" (13 mm) Socket wrench
- 3/4" (19 mm) Socket wrench
- Long rope
- Drill and 1/2" (13 mm) bit

Before you begin: Determine the layout and location of your dock. Use the rope to hold dock to shore.
Note: The shore anchors need to be equal height and distance to the water for the Stiff Arms to work properly.

Hardware Included

- (3) 1/2" x 2-1/2" Hex screws
- (3) 1/2" Stainless steel nylon self locking Hex nuts
- (3) 1/2" Washers
- Not available in metric

Hardware Needed

- (1) 2" id. (50Dn Sch 40) Galvanized pole
- (4) 1/2" x 3" (13 mm x 8 mm) Bolts
- (4) 1/2" (13 mm) Lock nuts
- (4) 1/2" (13 mm) Washers
- (2) 3/4" x 3-1/2" (19 mm x 9 cm) Bolts
- (2) 3/4" (19 mm) Lock nuts
- (2) 3/4" (19 mm) Washers

Instructions for:

- Stiff Arm Bracket (SAB1020)
- Stiff Arm Fitting (SAF1020)

Step 1

Have your shore anchor mounted in place (1a). Align Stiff Arm Bracket with shore anchor. Use 3 bolts for the 2000 Series docks and 2 bolts for the 1000 Series docks to align the holes in the Stiff Arm Bracket (1b).

Step 2

Place Stiff Arm Fitting with single end 12" to 13" (30.5 cm -33 cm) into pole. Drill two holes at least 6" apart through Stiff Arm Fitting and pole. Use 1/2" x 3" (19 mm x 8 cm) bolts, washer and locknut to secure. Insert the double ended Stiff Arm Fitting in opposite end of pole. Make sure bolt holes for mounting to Stiff Arm Bracket and shore anchor are parallel.

Step 3

Attach single ended Stiff Arm Fitting to Stiff Arm Bracket at dock. Secure with 1/2" (13 mm) bolt, washer and locknut (3a). Attach double ended Stiff Arm Fitting to shore anchor. Secure with 1/2" (13 mm) bolt, washer and locknut (3b).

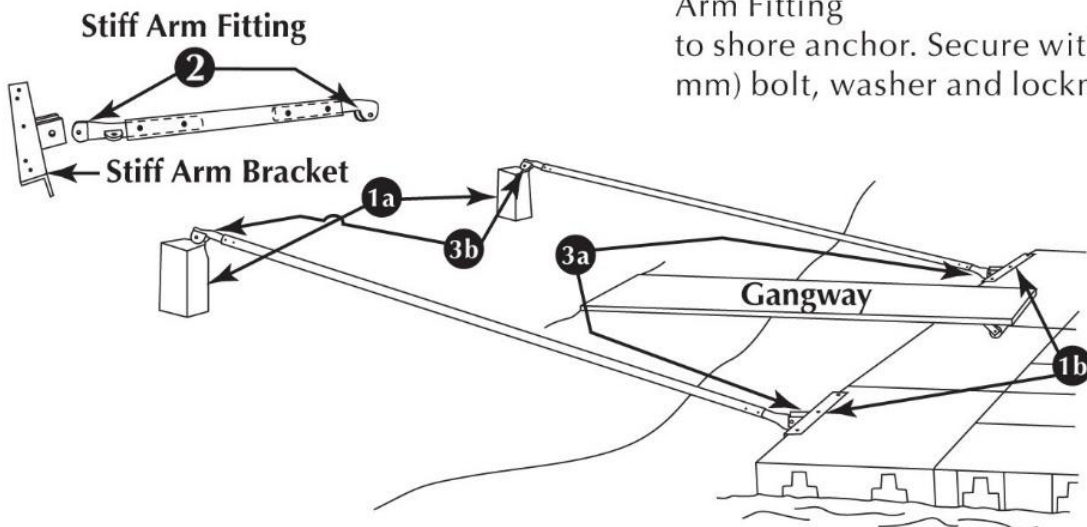

1501 Owner Avenue, Atlantic, IA 50022 USA

ventas@lobineando.com / info@lobineando.com



Piling Loop

www.connectadock.com

www.lobineando.com

Tools Needed

3/4" Deep socket wrench with
4" extension

Long rope for holding docks to
shore.

Not available in metric

**Before you begin: Determine the
layout and location of your dock.
Use the rope to hold the dock in
place. When possible, install
Piling Bracket on land.**

Hardware Included

- (2) 3/8" x 4" Carriage bolts
- (6) 3/8" x 1-1/2" Carriage bolts
- (8) 3/8" Nuts
- (8) 3/8" Washers

Step 1

Insert 1-1/2" carriage bolts up
through bottom of Piling Loop
Bracket. Place Roller Kit over
the bolts secure with washers and
nuts (**hand tighten only**).

Step 2

Insert two 1-1/2" carriage bolts in
the top holes on the side of the
Piling Loop Bracket. Secure bolts
with nuts (**hand tighten**). Lock
bolt into place by fitting square
on bolt into slot.

Step 3

Set the Piling Loop Bracket on the
edge of the dock. Align the holes
for the series of dock installed
**(1000 Series inner holes and 2000
Series outer holes)**. Insert two
4" carriage bolts. Secure with
washers and nuts.

Instructions for:

Piling loop (PL1010), (PL1012)
(PL1014), (PL1016), (PL1018)

Step 4

Remove the two nuts from the side
of the Piling Loop Bracket, with the
bracket secured to the dock the
carriage bolts will be held in place
(4a). Place the Piling Loop around
the piling. Secure the top carriage bolts
with washers and nuts. Insert the
lower two 1-1/2" carriage bolts and
secure with washers and nuts (4b).

Step 5

Center the Roller Kit with the piling
and tighten the nuts securely.

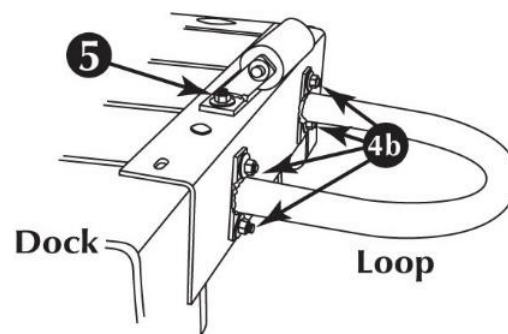
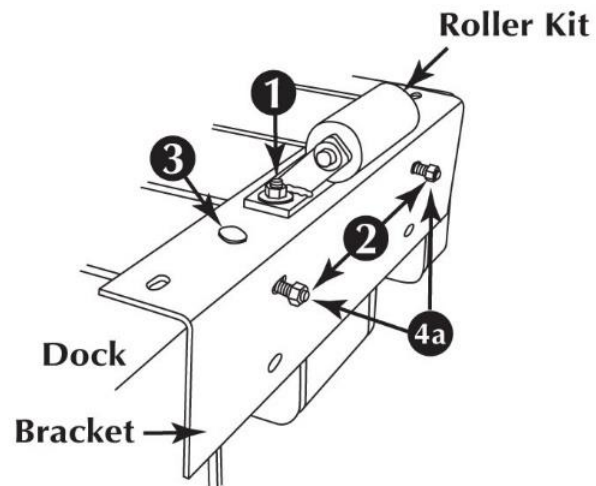

1501 Owner Avenue, Atlantic, IA 50022 USA

ventas@lobineando.com / info@lobineando.com





CONNECT-A-DOCK® Warranty — USA & Canada

Connect-A-Dock Inc. warrants to the original owner all polyethylene plastic components for eight (8) years from date of purchase to be free of defects in material and workmanship and to perform properly under normal usage and when *fully assembled according to the instructions provided at the time of purchase. All other accessories have a one (1) year limited warranty. *Fully assembled: Install float connectors into all float section sockets where other float sections will be attached. For a copy of the Connect-A-Dock complete warranty call Connect-A-Dock.



CONNECT-A-DOCK® Warranty — International

Connect-A-Dock Inc. warrants to the original owner all polyethylene plastic components for two (2) years from date of purchase to be free of defects in material and workmanship and to perform properly under normal usage and when *fully assembled according to the instructions provided at the time of purchase. All other accessories have a one (1) year limited warranty. *Fully assembled: Install float connectors into all float section sockets where other float sections will be attached. For a copy of the Connect-A-Dock complete warranty call Connect-A-Dock.



CONNECT-A-PORT™ Warranty — USA & Canada

Connect-A-Dock Inc. warrants to the original owner all polyethylene plastic components for five (5) years from date of purchase to be free of defects in material and workmanship. For a copy of the Connect-A-Port complete warranty call Connect-A-Dock.



CONNECT-A-PORT™ Warranty — International

Connect-A-Dock Inc. warrants to the original owner all polyethylene plastic components for two (2) years [one (1) year for commercial use] from date of purchase to be free of defects in material and workmanship. All other accessories have a one (1) year limited warranty. For a copy of the Connect-A-Port complete warranty call Connect-A-Dock.

Should you have a warranty claim, we may require that you provide a photograph or, in some cases, return the Connect-A-Dock part to the place of purchase. In order for warranty to be valid, original sales receipt must accompany warranty claim. NOTE: Shipping costs are not included in warranty.

NOTE: All plastic has an inherent tendency to create static electricity. If you have a concern, contact Connect-A-Dock.

1501 Owner Avenue, Atlantic, IA 50022 USA

1-877-742-3071 (toll free U.S.A. only) 1-712-243-2430

ventas@lobineando.com / info@lobineando.com